

ESD-5550/5570 Series - Speed Control Unit



Table 1.

ESD-5550/5570 Series Speed Control Units						
	Starting Fuel Control	Speed Ramping	Single Element Speed Switch (Overspeed)	2 Element Speed Switch (Overspeed & Crank Termination)	For Use with a Light Force Actuator	Interator Wind-Up Protection
ESD-5550	•	•	•			
ESD-5555	•	•	•			•
ESD-5556	•	•		•	•	•
ESD-5570	•	•	•		•	

INSTALLATION

The speed control unit is rugged enough to be placed in a control cabinet or engine mounted enclosure with other dedicated control equipment. If water, mist, or condensation may come in contact with the controller, it should be mounted vertically. This will allow the fluid to drain away from the speed control unit. Extreme heat should be avoided.

An overspeed shutdown device, independent of the governor system, should be provided to prevent loss of engine control, which may cause personal injury or equipment damage. Do not rely exclusively on the governor system electric actuator to prevent overspeed. A secondary shutoff device, such as a fuel solenoid, must be used.

*Solutions for combustion engines,
that work right from the beginning.*

Murgenthalstrasse 30
CH-4900 Langenthal
Phone: +41 (0)62 916 50 30
Fax: +41 (0)62 916 50 35
E-Mail: sales@huegli-tech.com



WIRING

Basic electrical connections are illustrated in **Diagram 2** (for the **ESD-5550**, **ESD-5555** and the **ESD-5570**) and **Diagram 3** (for the the **ESD-5556** only). Actuator and battery connections to **Terminals A, B, E, and F** should be #16 AWG (1.3 mm²) or larger. Long cables require an increased wire size to minimize voltage drops. The battery positive (+) input, **Terminal F**, should be fused for 15 amps as illustrated.

Magnetic speed sensor wires connected to **Terminals C and D** MUST BE TWISTED AND/OR SHIELDED for their entire length. The speed sensor cable shield should ideally be connected as shown in **Diagram 2** or **3**. The shield should be insulated to insure no other part of the shield comes in contact with engine ground, otherwise stray speed signals may be introduced into the speed control unit. With the engine stopped, adjust the gap between the magnetic speed sensor and the ring gear teeth. The gap should not be any smaller than 0.020 in. (0.45 mm). Usually, backing out the speed sensor 3/4 turn after touching the ring gear teeth will achieve a satisfactory air gap. The magnetic speed sensor voltage should be at least 1 VAC RMS during cranking.

ADJUSTMENTS

Before Starting Engine

Before starting the engine, check and/or adjust the POTs/switches to the following settings. See **Table 2** for the factory presets.

Adjustment/Switch	Potentiometer/Switch	Setting	Applicable Units
SPEED	25° turn	1470 Hz 1/- 50 Hz w/min trim	all
GAIN	270° turn	50%	all
STABILITY	270° turn	50%	all
DROOP	270° turn	0% (CCW)	all
IDLE	270° turn	1075± 75 Hz	all
STARTING FUEL RAMP	270° turn	100% (CW) Maximum Fuel	all
SPEED RAMP	270° turn	0% (CCW) Fastest	all
OVERSPEED	25° turn	100% (CW) Highest	all
CRANK TERMINATION	25° turn	0% (CCW) Lowest	ESD-5556 only
SW1 Lead Circuit	switch	ON	all
SW2 Soft Coupling	switch	OFF	all

Start Engine

The speed control unit governed speed setting is factory set at approximately engine idle speed. (1000 Hz., speed sensor signal) Crank the engine with DC power applied to the governor system. The governor system should control the engine at a low idle speed. If the engine is unstable after starting, turn the **GAIN** and **STABILITY** adjustments **CCW** until the engine is stable.

Adjusting Crank Termination (ESD-5556 only)

To protect the engine from harm the **CRANK TERMINATION** adjustment is factory set at full **CCW** [Lowest Setting]. To adjust **CRANK TERMINATION** speed setting, rotate the **CRANK** adjustment to full **CW**. Crank the engine and simultaneously turn the **CRANK** adjustment slowly **CCW** until the proper crank termination speed is reached. In operation, when the cranking termination set point is reached, the green **CRANK LED** will illuminate. (Cranking has terminated).

The **ESD-5556** is set for manual reset. To reinstate engine cranking, battery power must be removed and then reapplied which will recycle the control.

Adjusting Overspeed

When the engine is running at the desired speed, push and hold the **TEST** button. Rotate the **OVERSPEED** adjustment **CCW** until the red **OVERSPEED LED** lights and the relay energizes. Current to the actuator will be removed and the engine will shut off.

Release the **TEST** button. After the engine stops, press the **RESET** button or remove battery power. Restart the engine and it will return to the original speed setting. The overspeed function is now set to approximately 10% above the requested speed.

If a different value of overspeed setting is required, raise the engine speed to the desired overspeed value, i.e. 115%. Rotate the **OVERSPEED** adjustment **CCW** until the red **OVERSPEED LED** lights and the relay energizes.

WARNING

Always use the relay contacts provided to shut down the system by a means other than the governor or actuator. It is recommended that an overspeed protection system be routinely tested and verified during the scheduled service of equipment.

Governor Speed Setting

The governed speed set point is increased by a **CW** rotation of the **SPEED** adjustment control. Remote speed adjustment can be obtained with an optional **5K Speed Trim Control**. (See **Diagram 1.**)

Governor Performance

Once the engine is at operating speed and at no load, the following governor performance adjustment can be made.

- A. Rotate the **GAIN** adjustment **CW** until instability develops. Gradually move the adjustment **CCW** until stability returns. Move the adjustment one division further **CCW** to insure stable performance.
- B. Rotate the **STABILITY** adjustment clockwise until instability develops. Gradually move the adjustment counterclockwise until stability returns. Move the adjustment one division further to insure stable performance (270° pot).



- C. **GAIN** and **STABILITY** adjustments may require minor changes after engine load is applied. Normally, adjustments made at no load achieve satisfactory performance. A strip chart recorder can be used to further optimize the adjustments.

If instability cannot be corrected or further performance improvements are required, refer below to the **SYSTEM TROUBLESHOOTING** section.

Starting Fuel Adjustment

The engine’s exhaust smoke at start-up can be minimized by completing the following adjustments:

- A. Place the engine in idle by connecting **Terminals M & G**.
- B. Adjust the **IDLE** speed for as low a speed setting as the application allows.
- C. Adjust the **STARTING FUEL CCW** until the engine speed begins to fall. Increase the **STARTING FUEL** slightly so that the idle speed is returned to the desired level.
- D. Stop the engine.

Method 1		Method 2
Start the engine and accelerate directly to the operating speed (Gen Sets, etc.).		Start the engine and control at an idle speed for a period of time prior to accelerating to the operating speed. This method separates the starting process so that each may be optimized for the lowest smoke emissions.
Remove the connection between Terminals M & G . Start the engine and adjust the SPEED RAMPING for the least smoke on acceleration from idle to rated speed. If the starting smoke is excessive, the STARTING FUEL may need to be adjusted slightly CCW . If the starting time is too long, the STARTING FUEL may need to be adjusted slightly CW .	or	Replace the connection between Terminals M & G with a switch, usually an oil pressure switch. Start the engine. If the starting smoke is excessive, the STARTING FUEL may need to be adjusted slightly CCW . If the starting time is too long, the STARTING FUEL may need to be adjusted slightly CW . When the switch opens, adjust the SPEED RAMPING for the least amount of smoke when accelerating from idle speed to rated speed.

Idle Speed Setting

If the **IDLE** speed setting was not adjusted as detailed in ‘Starting Fuel Adjustment’ section, then place the optional external selector switch in the **IDLE** position. A **CW** adjustment to the **IDLE** adjustment control will increase the idle speed set point. When the engine is at idle speed, the speed control unit applies droop to the governor system to insure stable operation.

Speed Droop Operation

Droop is typically used for the paralleling of engine driven generators.

Place the optional external selector switch in the **DROOP** position. **DROOP** is increased by **CW** rotation of the **DROOP** adjustment control. When in droop operation, the engine speed will decrease as engine load increases. The percentage of droop is based on the actuator current change from engine no load to full load. A wide range droop is available with the internal control. Droop level requirements above 10% are unusual.

If droop levels experienced are higher or lower than these required, contact Huegli Tech for assistance.

After the droop level has been adjusted, the rated engine speed setting may need to be reset. Check the engine speed and adjust that speed setting accordingly.

Accessory Input

The **AUXiliary Terminal N** accepts input signals from load sharing units, auto synchronizers, and other governor system accessories. It is recommended that this connection from accessories be shielded as it is a sensitive input terminal.

If the auto synchronizer is used alone, not in conjunction with a load sharing module, a 30 resistor should be connected between **Terminals N** and **P**.

This is required to match the voltage levels between the speed control unit and the synchronizer.

When an accessory is connected to **Terminal N**, the speed will decrease and the speed adjustment must be reset.

When operating in the upper end of the control unit frequency range, a jumper wire or frequency trim control may be required between **Terminals G & J**. This increases the frequency range of the speed control to over 7000 Hz.

Accessory Supply

The +10 VDC regulated supply, **Terminal P**, can be utilized to provide power to GAC governor system accessories. Up to 20 mA of current can be drawn from this supply. Ground reference is **Terminal G**. **Caution: a short circuit on Terminal P could damage the speed control unit.**

Wide Range Remote Variable Speed Operation

Simple and effective remote variable speed can be obtained with the **ESD-5550/5570** Series control unit using an external potentiometer.

A single remote speed adjustment potentiometer can be used to adjust the engine speed continuously over a specific speed range. Select the desired speed range and corresponding potentiometer value. (Refer to **Table 4.**) If the exact range cannot be found, select the next higher range potentiometer. An additional fixed resistor may be placed across the potentiometer to obtain the exact desired range. Connect the speed range potentiometer as shown in **Diagram 1**.

To maintain engine stability at the minimum speed setting, a small amount of droop can be added turn the **DROOP** adjustment **CW**. At the maximum speed setting the governor performance will be near isochronous, regardless of the droop adjustment setting.

Contact Huegli-Tech for assistance if difficulty is experienced in obtaining the desired variable speed governing performance.

Diagram 1.

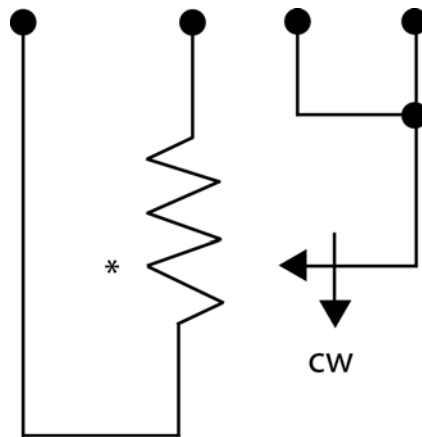

Table 4.

Variable Speed Range	
Speed Range	Potentiometer
900 Hz	1K
2,400 Hz	5K
3,000 Hz	10K
3,500 Hz	25K
3,700 Hz	50K

*Select Proper Potentiometer Value from **Table 4.**

SPECIFICATIONS

PERFORMANCE

Isochronous Operation/Steady State Stability	± 0.25% or better
Speed Range/Governor	1K-7.5K Hz continuous
Speed Drift with Temperature	± 1% Maximum
Idle Adjust CW	60% of set speed
Idle Adjust CCW	Less than 1200 Hz.
Crank Termination Adjustment Range	300-2200 Hz.
Droop Range	1 - 5% regulation*
Droop Adj. Max. (K-L Jumpered)	400 Hz., ± 75 Hz. per 1.0 A change
Droop Adj. Min. (K-L Jumpered)	15 Hz., ± 6 Hz. per 1.0 A change
Speed Trim Range	± 200 Hz.
Remote Variable Speed Range	500 - 7.5 Hz. or any part thereof
Speed Switch Adjustment Range	1000-10000 Hz.



Terminal Sensitivity

J 100 Hz., ± 15 Hz / Volt @ 5.0 K Impedance
 L 735 Hz., ± 60 Hz / Volt @ 65 K Impedance
 N 148 Hz., ± 10 Hz / Volt @ 1 Meg Impedance
 P 10 VDC Supply @ 20 ma Max
 Speed Switch Adjustment Range 1000-10000 Hz.

ENVIRONMENTAL

Ambient Operating Temperature Range -40° to +180°F (-40° to +85°C)
 Relative Humidity up to 95%
 All Surface Finishes Fungus Proof and Corrosion Resistant

INPUT POWER

Supply 12 or 24 VDC Battery Systems
 (Transient and Reverse Voltage Protected)**
 Polarity Negative Ground (Case Isolated)
 Power Consumption 50 mA continuous plus actuator current
 Actuator Current Range
 @ 77°F (25°C) - (Inductive Load) Min. 2.5Amps.. Max. 10Amps continuous***
 Speed Sensor Signal 0.5-120 Volts RMS
 Speed Switch Relay Contacts (N.O. and N.C.) 10 Amps

RELIABILITY

Vibration 1G @ 20 -100 Hz.
 Testing 100% Functionally Tested

PHYSICAL

Dimensions See Outline (DIAGRAM 1)
 Weight 1.8 lbs. (820 grams)
 Mounting Any Position, Vertical Preferred

* Droop is based on a speed sensor frequency of 4000 Hz. and an actuator current change of 1 amp from no load to full load. Applications with higher speed sensor signals will experience less percentage of droop. Applications with more actuator current change will experience higher percentages of droop. See droop description for specific details on operation of droop ranges. When used with the ADC-100 actuator the droop percentage will be less due to the actuators low current consumption.

** Protected against reverse voltage by a series diode. A 15 amp fuse must be installed in the positive battery lead.

*** Protected against short circuit to actuator (shuts off current to actuator), unit automatically turns back on when short is removed.

Diagramm2 for ESD-5550, ESD-5555 and ESD-5570 only



Diagramm for ESD-5556 only



SYSTEM TROUBLESHOOTING

SYSTEM INOPERATIVE

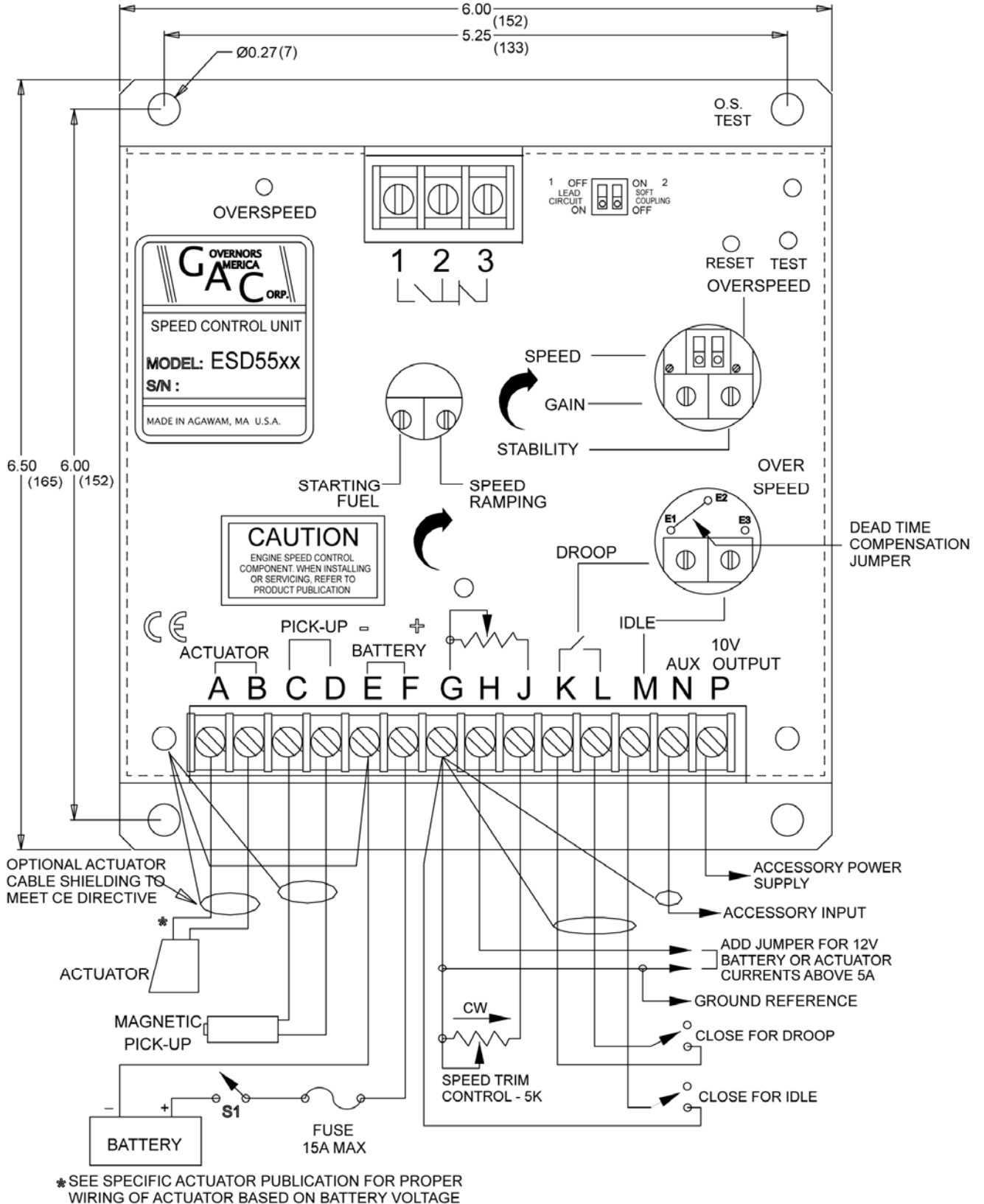
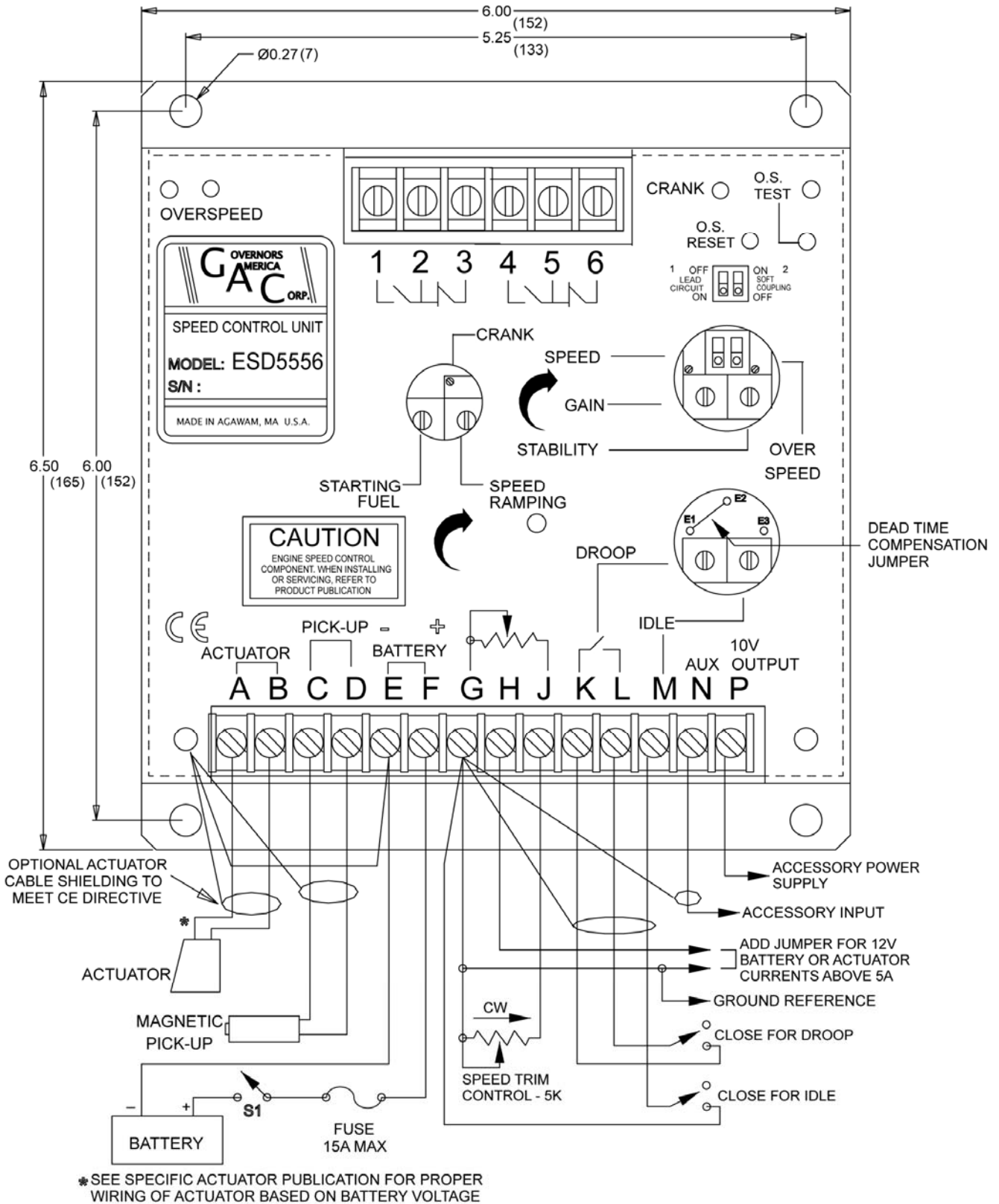
If the engine governing system does not function, the fault may be determined by performing the voltage tests described in Steps 1, 2, 3 and 4. [+] and [-] refer to meter polarity. Should normal values be indicated as a result of following the troubleshooting steps, the fault may be with actuator or the wiring to the actuator. See the actual publication for testing details

Steps	Terminals	Normal Reading	Probable Cause of Abnormal Reading
1	F(+) & E(-)	Battery Supply Voltage 12 or 24 VDC	1. DC battery power not connected. Check for blown fuse. 2. Low battery voltage. 3. Wiring error.
2	C & D	1.0 VAC RMS min., while cranking.	1. Gap between speed sensor and gear teeth too great. Check gap. 2. Improper or defective wiring to the speed sensor. Resistance between Terminals C & D should be 30 to 1200 fl.
3	P(+) & G(-)	10 VDC, Internal Supply.	1. Short on Terminal P. (This will cause a defective unit.) 2. Defective Speed Control.
4	F(+) & A(-)	1.0 - 2.0 VDC while cranking.	1. Speed Adjustment set too low. 2. Short/open in actuator wiring. 3. Defective speed control. 4. Defective actuator. See Actuator Troubleshooting.

UNSATISFACTORY PERFORMANCE

If the engine governing system functions poorly, perform the following test.

Symptom	Test	Probable Fault
Engine overspeeds.	1. Do not crank. Apply DC power to the governor system.	1. Actuator goes to full fuel. Then, disconnect speed sensor at Terminals C & D. If the actuator is still at full fuel - the speed control is defective. If the actuator is still at minimum fuel fuel position - erroneous speed signal. Check speed sensor data.
	2. Manually hold the engine at the desired running speed. Measure the DC voltage between Terminals A (-) & F(+) on the speed control unit.	1. If the voltage speed reading is 1.0 to 2.0 VDC; a.) SPEED adjustment is set above desired speed. b.) Defective speed control unit. 2. If the voltage reading is above 2.0 VDC; a.) Actuator or linkage binding. 3. If the voltage reading is below 1.0 VDC; a.) Defective speed control unit. 4. Gain set too low.
Actuator does not energize fully.	1. Measure the voltage at battery while cranking.	1. If the voltage is less than 7VDC for a 12VDC system or less than 14VDC for a 24VDC system, replace the battery if it is weak or undersized.
	2. Momentarily connect Terminal A & F. The actuator should move to full throttle position.	1. Actuator or battery wiring in error. 2. Actuator or linkage binding. 3. Defective actuator. See actuator troubleshooting. 4. Fuse opens. Check for short in actuator or actuator wiring harness.
Engine remains below desired governed speed.	1. Measure the actuator output. Terminal A & B, while running under governor control.	1. If voltage measurement is within approx. 2 volts of the battery supply voltage, then fuel control restricted from reaching full fuel position. Possible due to interference from the mechanical governor, carburettor spring or linkage alignment. 2. Speed setting too low.

Insufficient Magnetic Speed Signal

A strong magnetic speed sensor signal will eliminate the possibility of missed or extra pulses. The speed control unit will govern well with 0.5 volts RMS speed sensor signal. A speed sensor signal of 3 volts RMS or greater at governed speed is recommended. Measurement of the signal is made at **Terminals C** and **D**.

The amplitude of the speed sensor signal can be raised by reducing the gap between the speed sensor tip and the engine ring gear. The gap should not be any smaller than 0.020 in (0.45 mm). When the engine is stopped, back the speed sensor out by 3/4 turn after touching the ring gear tooth to achieve a satisfactory air gap.

Electromagnetic Compatibility (EMC)

EMI SUSCEPTIBILITY - The governor system can be adversely affected by large interfering signals that are conducted through the cabling or through direct radiation into the control circuits.

All GAC speed control sensors contain filters and shielding designed to protect the unit's sensitive circuits from moderate external interfering sources. Although it is difficult to predict levels of interference, applications that include magnetos, solid state ignition systems, radio transmitters, voltage regulators or battery chargers should be considered suspect as possible interfering sources.

If it is suspected that external fields, either those that are radiated or conducted, are or will affect the governor systems operation, it is recommended to use shielded cable for all external connections. Be sure that only one end of the shields, including the speed sensor shield, is connected to a single point on the case of the speed control unit. Mount the speed control to a grounded metal back plate or place it in a sealed metal box.

Radiation is when the interfering signal is radiated directly through space to the governing system. To isolate the governor system electronics from this type of interference source, a metal shield or a solid metal container is usually effective.

Conduction is when the interfering signal is conducted through the interconnecting wiring to the governor system electronics. Shielded cables and installing filters are common remedies.

In severe high-energy interference locations such as when the governor system is directly in the field of a powerful transmitting source, the shielding may require to be a special EMI class shielding. For these conditions, contact Huegli Tech for specific recommendations.

Instability

Instability in a closed loop speed control system can be categorized into two general types.

PERIODIC appears to be sinusoidal and at a regular rate. **NON-PERIODIC** is a random wandering or an occasional deviation from a steady state band for no apparent reason.

Switch C1 controls the "Lead Circuit" found in the ESD-5550/5556/5570. The normal position is "ON." Move the switch to the "OFF" position if there is fast instability in the system.

Switch C2 controls an additional circuit added in the ESD-5550/5570 that is designed to eliminate fast erratic governor behavior, caused by very soft or worn couplings in the drive train between the engine and generator. The normal position is "OFF." Move to the "ON" position if fast erratic engine behavior due to a soft coupling is experienced.

The **PERIODIC** type can be further classified as fast or slow instability. Fast instability is a 3 Hz. or faster irregularity of the speed and is usually a jitter. Slow periodic instability is below 3 Hz., can be very slow, and is sometimes violent.

If fast instability occurs, this is typically the governor responding to engine firings. Raising the engine speed increases the frequency of instability and vice versa. In this case, placing switch C1 in the "OFF" position will reduce the speed control unit's sensitivity to high frequency signals. Readjust the **GAIN** and **STABILITY** for optimum control. Should instability still be present, the removal of E1 to E2 jumper may help stabilize the engine. Post locations are illustrated in Diagram 1. Again, readjust the **GAIN** and **STABILITY** for optimum control. Interference from powerful electrical signals can also be the cause. Turn off the battery chargers or other electrical equipment to see if the system instability disappears.



Slow instability can have many causes. Adjustment of the **GAIN** and **STABILITY** usually cures most situations by matching the speed control unit dynamics. If this is unsuccessful, the dead time compensation can be modified. Add a capacitor from posts E2 to E3 (negative on E2). Post locations are illustrated in Diagram 1. Start with 10 mfd. and increase until instability is eliminated. The control system can also be optimized for best performance by following this procedure.

If slow instability is unaffected by this procedure, evaluate the fuel system and engine performance. Check the fuel system linkage for binding, high friction, or poor linkage. Be sure to check linkage during engine operation. Also look at the engine fuel system. Irregularities with carburetion or fuel injection systems can change engine power with a constant throttle setting. This can result in speed deviations beyond the control of the governor system. Adding a small amount of droop (**Jumper K-L**) can help stabilize the system for troubleshooting.

NON-PERIODIC instability should respond to the **GAIN** control. If increasing the gain reduces the instability, then the problem is probably with the engine. Higher gain allows the governor to respond faster and correct for disturbance. Look for engine misfirings, an erratic fuel system, or load changes on the engine generator set voltage regulator. If the throttle is slightly erratic, but performance is fast, move switch C1 to the "OFF" position. This will tend to steady the system.

If unsuccessful in solving instability, contact Huegli Tech for assistance.

DECLARATION OF CONFORMITY TO EC DIRECTIVES

Application to Council Directives	Heavy & Light Industrial Applications
Standard to which Conformity is Declared	EN55011, EN50081-2, and EN50082-2
Manufacturer's Name	GOVERNORS AMERICA CORPORATION
Manufacturer's Address	Agawam, MA 01001 USA
Importer's Name	
Importer's Address	
Type of Equipment	ESD-5550/5570 Series
Serial Number	Above K 2299
Year of Manufacture	1996 and later
Place:	Agawam, MA USA
Date:	12-01-96
Signature:	
Full Name:	Mr. William Ferry
Position:	President

In order to be compliance with the above directives, the installer is obligated to install the equipment in strict accordance with the following guidelines.

1. The Speed Control Unit must be mounted against the metal ground plane with four bolts which make a positive electrical connections between the case and the back plane or a backing plate, PL128 available from Huegli Tech, must be installed.
2. The magnetic pickup must be connected to the speed control using shielded cable as shown in the wiring diagrams.
3. All shielded cable connections to the speed control must be connected to the case at the corner threaded connection per the wiring diagram.
4. The BATTERY minus connection at Terminal E must also be additionally jumpered to the case at the corner.
5. Shielded cable for the actuator is recommended to minimize the actuator's slight movement during fast voltage transients. The installer's choice of not using shielded cable may cause the actuator to move more than slightly during these transients. However, no failures should be experienced.
6. The installer must refer to the wiring diagram in the literature for proper electrical connects.