

Developing Technology for Tomorrow's Power Needs.

Denyo

HIGH-PERFORMANCE SINGLE PHASE GENERATOR SETS

DCA-ESX·SPX·XY

SINGLE PHASE TYPE

(5~60kVA)



DCA-10ESX



DCA-11XY

POWER ON

Denyo Co., Ltd.

Denyo's New Generator Minimal Voltage Fluctuation and Wave Distortion.

Voltage Variation Less Than $\pm 1.0\%$

A unique high-performance Denyo automatic voltage regulator maintains superb output stability by keeping voltage variation to under $\pm 1.0\%$.

In-Built Convenience

A standard "emergency stop device" will shut down the generator automatically when a malfunction is detected and in addition, an "in-built breaker" protects the generator from overloads (The warning light for models up to and including DCA-15ESX will illuminate when Low Oil Pressure, High Water Temperature and Insufficient charging are detected. The OK monitor used in DCA-18ESX and higher models will illuminate when Low Fuel Level, Dust and other Foreign Particles inside the Unit, Low Oil Pressure and High Water Temperature are detected)

An optional "earth leakage relay" reduces the risk of the user been electrocuted.

Minimal Waveform Distortion

A damper coil and generator design refinements keep waveform distortion to negligible levels, even under SCR and compact X-ray unit loads.

Quiet Operation

Original sound-proofing technology reduces the noise level to under 65dB(7m). These generators are classified as super Low Noise Construction Machine according to the standards issued by the Japanese Ministry of Construction.

Low-Cost Operation

The 4-pole generator design enables use of economical low engine speeds within the 1,500 to 1,800 rpm range. The efficient generator with 4-cycle diesel engine further reduces fuel consumptions.



Lightweight and Compact

New style and design make the generators lighter in weight and compact, compared to previous models. Ideal usages include ambulances, remote telecast vans and as a back-up power supply for computer systems.

Breather System Engines

As the Breather System engine does not exhaust blow-by gas, the inside of the generator always keeps clean.

Automatic Fuel Bleeder Device

(used in DCA-6ESX2,10ESX,15ESX,18ESX,60ESX and DCA-XY Series)

Just turn the starter switch on, and it releases air from the fuel automatically. It will neither taint the inside of the machine nor the operator's hand.

Sets Assurance tion Rate



Sound-Proof Series



Denyo's original sound-proofing technology reduces the noise level to under 65dB(A) (7m). The compact design enables easy installation.

DCA-10ESX



DCA-15ESX



Optional Emergency Backup System

Connecting the optional automatic start panel enables use as an emergency backup system, only if the generator has had the appropriate modifications.

The hanging automatic start panel



Smooth Fuel Filling System

(DCA-XY Vehicle Mount series)

A mechanical pump on vehicle models enables a dependable, easy replenishment of the generator fuel supply from the vehicle's fuel tank.

Optional Slowdown Unit

(for models higher than DCA-30SPX)

Automatic idling function; a warming-up for 5 to 180 seconds according to the temperature at the starting and a low speed cooling-down at the stopping are controlled.

Slowdown function; as the engine speed is changed automatically according to the capacity of loads, it enables a reduction in the fuel consumption.

Using the optionally available remote control unit, the engine and the above functions can be operated from a distance.

Vehicle-Mount Series



Lightweight and compact dimensions make XY series units ideal for ambulance, remote telecast van and similar vehicle applications.



DCA-11XY
With Optional Radiator Duct

Specifications

Item	Model	Sound-Proof Type												Vehicle-Mount Type*1							
		DCA-6ESX2		DCA-10ESX		DCA-15ESX		DCA-18ESX		DCA-30SPX		DCA-40SPX		DCA-60ESX		DCA-7.5XY		DCA-11XY		DCA-17XY	
Generator	Frequency Hz	50	60	50	60	50	60	50	60	50	60	50	60	50	60	50	60	50	60	50	60
	Output kVA	5	6	8	10	13	15	14	18	24	30	33	40	50	60	6.5	7.5	8.5	11	14	17
	Voltage V	50Hz:100,110,200,220,230,240 60Hz:100,110,120,200,220,240						50Hz:100/200 ~ 110/220 60Hz:100/200 ~ 120/240						50Hz:100,110,200,220,230 60Hz:100,110,120,200,220,240							
	Rotating Speed rpm	1500	1800	1500	1800	1500	1800	1500	1800	1500	1800	1500	1800	1500	1800	1500	1800	1500	1800	1500	1800
	Power Factor	1.0																			
	No. of Phase	Single Phase (2-wire type) *2						Single Phase (3-wire type)						Single Phase (2-wire type) *2							
	Rating	Continuous																			
	Excitation	Brushless (with AVR)																			
	No. of Poles	4																			
Diesel Engine	Model	KUBOTA D905-K2B		KUBOTA D1403-KA		KUBOTA V2203-KB		ISUZU AA-4LE2		ISUZU B-4BG1		ISUZU A-6BG1		HINO J08C-P		YANMAR 3TNE74		YANMAR 3TNE82A		YANMAR 4TNE88	
	Type	Inlined, Swirl Chambered						Inlined, Direct Injected						Inlined, Direct Injected							
	No. of Cylinders, Bore, Stroke mm	3-72×73.6		3-80×92.4		4-87×92.4		4-85×96		4-105×125		6-105×125		6-114×130		3-74×78		3-82×84		4-88×90	
	Piston Displacement L	0.898		1.393		2.197		2.179		4.329		6.494		7.961		1.006		1.330		2.189	
	Rated Output PS/rpm	8.7/1500	10.5/1800	13.7/1500	16.9/1800	21.5/1500	25.5/1800	26/1500	32/1800	46.5/1500	56/1800	64/1500	78/1800	95.2/1500	113/1800	11/1500	13.5/1800	14.9/1500	17.9/1800	24.5/1500	29.4/1800
	Rated Output KW/min ⁻¹	6.4/1500	7.7/1800	10.2/1500	12.4/1800	15.8/1500	18.8/1800	19.1/1500	23.5/1800	34.2/1500	41.2/1800	47.1/1500	57.4/1800	70/1500	83/1800	8.1/1500	9.9/1800	10.9/1500	13.2/1800	18/1500	21.6/1800
	Battery X Quantity	55B24L×1		80D26R×1						75D31R×2		95D31R×2		12V-45Ah×1*3		12V-70Ah×1*3		12V-80Ah×1*3			
	Fuel	ASTM No.2 Diesel Fuel, or Equivalent																			
	Fuel Tank Capacity L	36		62		62		70		100		125		185		None (can utilise the vehicle's fuel tank)					
	Fuel Consumption*4 L/h	1.6	1.9	2.3	2.9	3.5	4.1	3.0	3.8	5.4	6.6	8.0	10.2	10.7	13.4	1.8	2.0	2.0	2.6	3.3	4.0
Dimensions, Weight, etc.	Length:L mm	1230		1390		1540		1540		2000		2420		2750		925(1105)*5		1036(1256)*5		1280(1530)*5	
	Width:W mm	650		650		650		680		880		880		1100		574		585		636	
	Height:H mm	760		900		900		900		1250		1250		1400		690		725		750	
	Dry Weight kg	368		503		579		564		1180		1410		1860		225(237)*5		293(306)*5		400(415)*5	
	Sound Level 7mdB(A)*6	52	56	58	61	59	63	59	60	62	63	59	63	60	64	68	70	69	71	73	76

*1 Vehicle mount series are mono-frequency generators.

*2 3-wire type is available as option. *3 NO(to be installed by client) *4 Fuel consumption is based on operation at 75% load.

*5 The figures shown in parentheses are for the weight and dimensions including the optional Radiator Duct.

*6 Sound level reflects high-speed no-load operation and is calculated by averaging the measurements at four points, each 7 meters from the source.

Dimensions(Sound-proof Type)

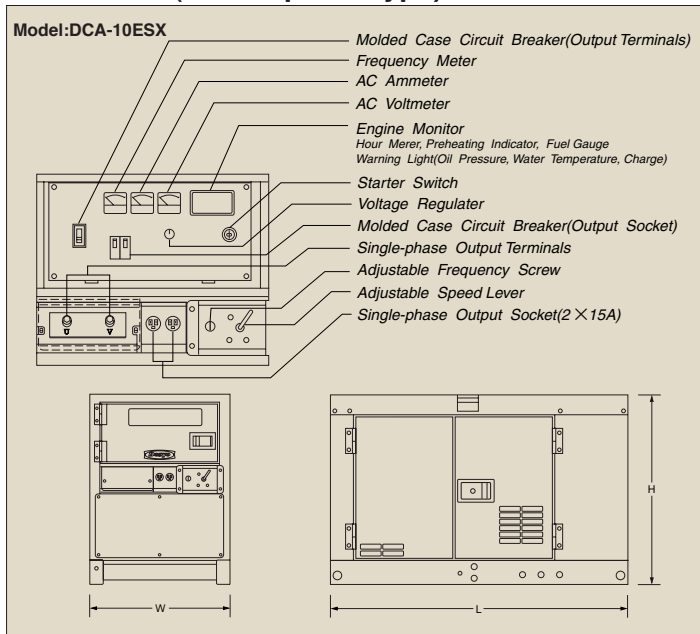

Dimensions(Vehicle-Mount Type)

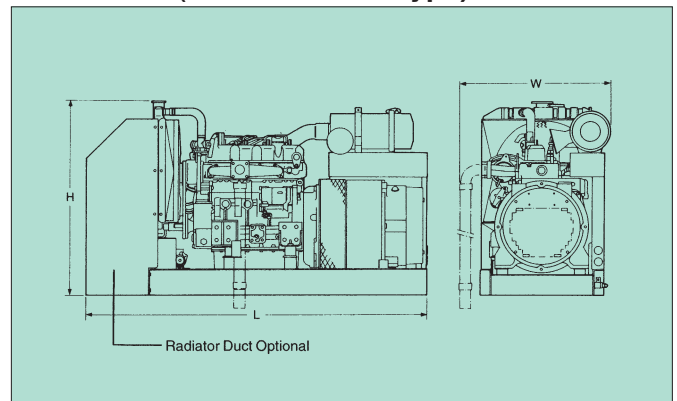

ISO 9001 Certified
Colors of products would be different from printed ones of catalogues.
The Specifications given herein are subject to change without notice.

Direct inquiries to the nearest Denyo distributor or to Denyo Co., Ltd.



Denyo Co., Ltd.

Head office : 2-8-5, Nihonbashi-horidomecho, Chuo-ku, Tokyo
103-8566, Japan

Tel.:+81-3-6861-1111 Fax :+81-3-6861-1181

http://www.denyo.co.jp