

Te 803 Electronic Controller

Service, Operation & Technical Information Manual

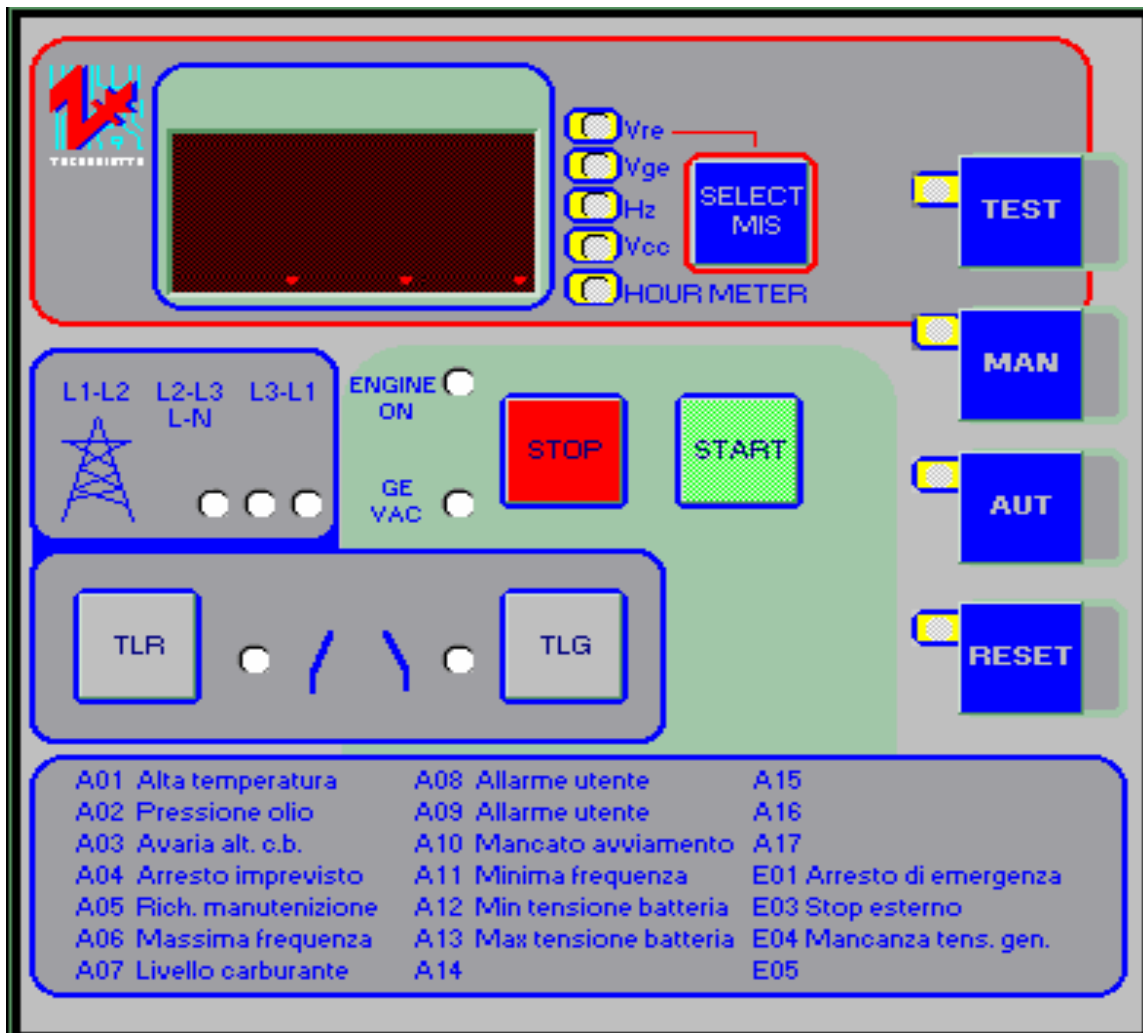

WARNING! Technical descriptions and data given in this document are accurate, to the best of our knowledge, but can be subject to change without prior notice so no liabilities for errors, omissions or contingencies arising there from are accepted. Moreover, the TE803 should be set up and used by trained personnel and, in any case, in compliance to current installation standards, to avoid damages or safety hazards.

1. OPERATING PROCEDURES FOR AUTOMATIC CONTROL PANEL

[Warning!] Carefully study the instructions of your automatic control panel before starting your Genset set, so you will be able to operate your Genset safely.

[Warning!] Before starting your generator, check that there are no obstructions around it.

[Caution!] When starting the Genset the first time or after a long storage, let the engine warm up at least 5 minutes. This prolongs the life of the Genset.

[Warning!] The automatic control panel should only be set up and operated by trained personnel. Local codes must be followed in order to avoid equipment damage, and /or personal injury up to and including death.

[Caution!] Always check that the technical data printed on the nameplate corresponds to your specific requirements.

These products have been manufactured to minimize RFI that could damage or interfere with equipment.

Note: Due to a constant drive to improve the product through research and development, all procedures, specifications and equipment are subject to change without notice.

1.1 OPERATING PROCEDURES - GENERAL -

- Programming of the control panel should be done by trained personnel.
- Any programming done to the control panel should be performed with the load disconnected.
- Electrical connections must be carried out in compliance with local codes. AC cables, particularly, must be sized and placed so that the cable does not attain temperatures over 50°C room temperature.
- It is necessary to check that cables have not loosened at the respective terminals and to remove any dust or other materials that have fouled the control panel during installation. The cleaning must be done by means of a vacuum, avoiding blowing dust into the control panel with air.
- Connections to the terminal board must be made using a cable of correct cross section, per electric diagram.
- To open the control panel front door use the special key supplied with the control panel. Only trained personnel should have access to this key.
- To protect from electric shocks and any atmospheric discharges, it is necessary to provide adequate earthen ground.

1.2 TECHNICAL TERM DEFINITION

Refer to the following definitions whenever these terms are mentioned in the manual:

Program Options: This is the set up of the controller. This is done before or during the installation of the Genset. All operating times and calculations that affect the system functioning can be set up and the parameters are stored in a permanent memory. Only trained personnel can reach this function and it is password protected.

Options, on the contrary, can be adjusted at any time without a password.

Starting Cycles: The sequence of diesel Genset starting is as follows: first glow plugs are energized (programmable duration), and then the fuel solenoid valve is activated. After these two steps the control panel enters into a start interval (programmable duration), alternating with intervals of cool down (programmable duration). Once the engine is on, the starting attempts stop immediately.

The sequence of gaseous Genset (MP5G19) starting is as follows: first the gas valve is activated; for the first starting attempt primer is energized. The Electronic Ignition is energized at the same time as the gas valve; to avoid over-speed alarm RPM governor (this device is described in Appendix B) is energized after a time delay (after cranking). After these steps the control panel enters into a start interval (programmable duration), alternating with intervals of cool down (programmable duration). Once the engine is on, the starting attempts stop immediately.

Genset Stopping Procedure: The transfer switch opens and the Genset continues to run for a cool down period (programmable) at the end of which the fuel solenoid valve(for MPD17-21) or the gas valve + Electronic Ignition + rpm governor (for MPD19) are switched off and the engine stops. In case of emergency stop, the above-mentioned procedure takes place without considering the cool down time.

Engine On: The engine is considered on when the “engine ON “ signal, which comes out of the engine alternator battery charger, exceeds the programmed value. Its led shows the engine-on signal. For safety reason generator output voltage is also monitored to verify that the engine is running.

Alarms On: Oil pressure and high temperature alarms are enabled after a delay time (programmable) greater than the engine-on signal time. The “engine ON” led flashing indicates the engine is on but the alarms are not enabled, and becomes on steady when the engine is running and the alarms are enabled. During the stopping cycle, the alarms are disabled and the fuel solenoid valve close simultaneously.

Utility-Off: The utility-off signal occurs when the utility voltage is out of the fixed limits (lower than the minimum fixed values or higher than the maximum fixed values) and remains in that state longer than the programmable time. This causes the transfer switch to transfer to the emergency position (after Generating set has started and met requirements).

Utility-On: In the same way, the utility-on signal occurs when (as a programmable time is exceeded) the voltage are inside the fixed limits. The transfer switch function will depend on the selected operating procedure.

Generator-On: Generator-On signal works as the utility-on signal described above. The Voltages and delay intervals are independent.

Utility/Genset and Generator/Utility Switching: The remote control switches between the utility and Genset. A delay time occurs to avoid simultaneous connections.

1.3 Te803 CONTROLLER MAIN FEATURES

- Control based on 11 MHz Intel 80c552 microprocessors.
- 32Kbyte EPROM memory program
- 32Kbyte static RAM data memory
- 512 Word EPROM non-volatile memory
- Operator display of 3 figures LED display
- Function/State/Alarm display by means of 15 LED's.
- Diaphragm button strip with 7 mechanical push buttons.
- Voltages measure at real effective value (RMS.).
- All programming options accessible from the frontal side without dip switch (by software in permanent memory)
- Programming options protected by admittance key
- RS 232 serial interface for remote control by computer or modem

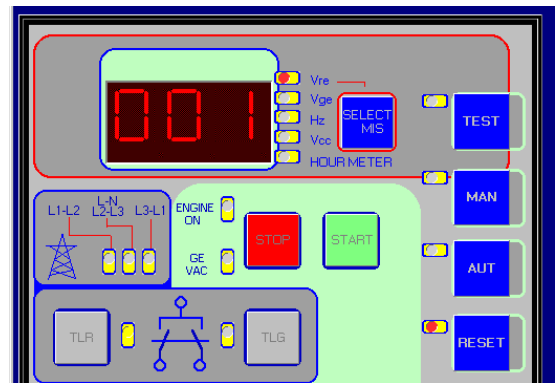

1.4 Te803 CONTROLLER DESCRIPTION

The following devices are placed on the control panel of the card:

- Reset/Manual/Test buttons (to select operating procedures)
- Measure button (to select display)
- Start/Stop buttons (start/stop of the generator)
- Reset/Man/Auto/Test LED (selected operating procedure signals)
- LED volt, hertz, V. Battery, hour meter (selected measure signals)
- LED battery (battery charger condition)
- LED starting failure (Genset starting failure)
- LED engine on (Genset on)
- LED alarms (alarms on)
- LED TLR (utility mains), TLG (Generator AC power leads) indicates power source being delivered to the load.
- 3 figure display (measures, alarms, etc...display)

1.5 MEASURE DISPLAY

The following measures can be selected on the display:

- Utility/Genset voltage (Volt)
- Frequency of Genset signal (Hertz)
- Battery voltage (Vdc)
- Genset working hours (hour meter)

A light also signals which measurement is being displayed (AC volts, freq., Battery Vdc, run hours). To select another measure on the display press the measure button. When you select voltage measure and the Genset is off, the display will show Utility voltage. The displayed value of utility and Genset voltage is in 1 volt increments, the frequency at 0.1 Hz, the battery voltage at 0.1 volt and working hours at 1 hour (even if the internal time stored is measured in minutes).

1.6 DIGITAL CONTROLLER: REMARKS

The digital controller is a device that displays RMS voltage measurements and at the same time, accurately and quickly controls all functions that are needed for the proper operation of your genset.

1.7 CONTROLLER FACE DESCRIPTION

- 3 Figure Display (to show measures, alarms, messages and errors)
- Reset-Auto-Man-Test Buttons (to select operating procedures)
- Select-MIS buttons (to select what display)
- Start-Stop buttons (to start and stop the Genset manually)
- TLR-TLG Buttons (to switch utility mains and Genset remote control switches manually)
- Reset-Auto-Man-Test LED (to show the selected operating procedures)
- VRE-VGE-HZ-VCC-Hour Meter LED (to show the selected measure)
- Engine-on LED (to show the engine is in operation)
- Utility Voltage-On LED (L1-L2-L3/L-N,L3-L1) and Genset (VAC)
- Utility and Genset remote control switches LED

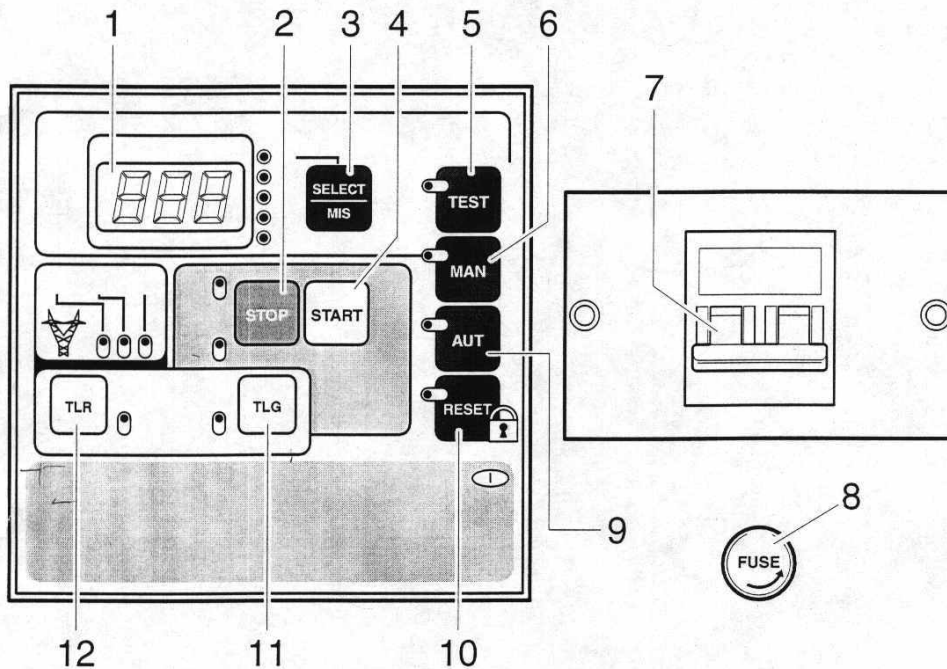

- 1. Display
- 2. Stop Button
- 3. Measure Selecting Button
- 4. Start Button

- 5. Test Button
- 6. Manual Operation
- 7. Circuit Breaker
- 8. Fuse
- 9. Automatic Operation

- 10. Reset
- 11. Utility Remote Control Switch
- 12. Genset Remote Control Switch

1.8 OPERATING PROCEDURES

Note: this section contains all parameters and functions, which are programmable through the access to the two menus of setup and option. Please refer the descriptions when you need more information.

The digital controller performs 4 different functions:

- **Reset**
- **Automatic**
- **Manual**
- **Test**

You select the procedure you need by selecting its button and its LED lights up. It is always possible to skip from one operating procedure to another.

Warning! For safety reasons, after controller power-up, the operating procedure becomes always RESET.

When one of the four operating procedure LED's is flashing, it shows that the unit is being controlled by a supervision system (remote control).

RESET: When using the reset operating procedure, the controls are not operational. You set all displayed alarms to zero as if the unit was not connected. Only the general alarm is still in operation. Control entries and the siren alarm are disconnected as well.

Signaling LED's, on the contrary, are still in operation and can show measures and alarms.

When changing from Man/Auto/Test to reset and the Genset is in operation, the controller stops the Genset automatically without waiting for the cooling interval (option 09).

AUTOMATIC: In the Automatic mode the Genset starts when the utility voltage goes out of limits (options 01-02) and its respective control switch is off. After the programmed delay (option 03), Utility remote control switch gets switched off and the Genset start cycle begins.

When the Genset is running and its voltage reaches the fixed limits (options 05-06), the Genset remote control switch closes. The Genset goes on working until the utility voltage is restored. Once the utilities are back, the remote control switches exchange position (option 04) and the Genset carries out the stop cycle.

When the Genset is running, however, it can be stopped by means of the stop button. In automatic procedure both the remote start and stop are enabled.

MANUAL: In the manual mode the Genset can be started or stopped simply by pushing the respective start and stop buttons. The start button begins the start cycle while the stop button begins the stop cycle.

After pushing the stop button you can stop it from beginning the stop cycle by immediately pushing the start button.

By pressing (and holding) the Manual button and the TLG (Genset) button you can change from Utility power to Genset power.

You can do vice versa (from Genset to Utility power) by pressing and holding the Manual button and the TLR (Utility) button.

From one button pressing command to another, an interval delay takes place as previously programmed (setup 15). Passing from auto to test or manual does not affect the operation of the generator.

TEST: In test procedures the Genset begins the start cycle. If the Utility power drops out while the Genset is in test mode the controller will over ride this function and switch the Generator to the load. Once the Utility voltage returns, the load will stay on the generator. If the auto mode is enabled, the controller will transfer the load to the Utility and will start the stop cycle of the generator.

AUTOMATIC TEST: The automatic test is a periodic check that is carried out by the control panel at fixed intervals (interval can be fixed during option setup). If the control panel is in automatic mode and the automatic test has been enabled, the Genset runs for a fixed period before it stops.

AUTOMATIC TEST CONNECTION/DISCONNECTION: To connect or disconnect the automatic test function push the measure button and, while keeping it pressed, also push the test button. The display will show the following messages:

- Off if the test is disconnected.
- On .g if the test is connected (g stands for the number of interval days programmed during option programming). At this stage push start if you want to enable the function or stop if you want to disable the function. Pushing the reset button once, stores the changes and returns the Genset to the normal operating procedure.

WORKING HOUR CALCULATION: After the engine starting, the working minutes are counted. The calculation, expressed in hours, can be shown on the display. The calculation continues even in case of disconnection of the electrical input and cannot be set to zero by the user.

PERIODIC MAINTENANCE INTERVAL: By means of set up, a periodic maintenance interval, expressed in hours, is set. When the working minutes reach the fixed amount, the display shows the code of maintenance request. The control panel, however, goes on working normally. Pushing reset you set to zero the calculation and the message disappears.

1.9 ALARMS AND DESCRIPTION CODES:

The display can show certain codes to signal emergency or specific situations. The message disappears only when those emergency conditions have disappeared and the user has pressed the reset button. Follow the schedule codes below:

➤ **A01 Temperature Alarm**

This message appears when – during engine operation the temperature sensor detects an over temperature condition. In this case the Genset remote control switch opens and the Genset stops at once.

➤ **A02 Oil Pressure Alarm**

It operates like the one mentioned above, but it refers to the sensor for insufficient oil pressure.

➤ **A03 Charger Alternator Failure Alarm**

This alarm appears when the Genset is running and the Genset voltage is within limits, the battery charger alternator signal is missing (lower than setup –06 for more than setup –14 time delay).

➤ **A04 Mechanical Alarm**

This indicates that the engine is not operating for a non-electrical problem.

➤ **A05 Request for Maintenance**

This alarm occurs when the periodic maintenance interval has been exceeded. This interval (in hours) is programmed in the setup menu. The Genset, however, goes on working normally.

➤ **A06 Runaway Speed Alarm**

This alarm occurs when frequency (Engine RPMs) exceeds the value fixed by setup. The transfer switch opens and the Genset stops immediately.

➤ **A07 Fuel Alarm (Diesel)**

Indicates low fuel level. Factory default is indication only. This can be programmed to shutdown.

➤ **A08 Low Water level Alarm**

Indicates low coolant level inside the engine radiator. This is programmed to shutdown.

➤ **A09 Dirty Air Filter Alarm**

Indicates that the air filter is clogged. This is programmed to shutdown.

➤ **E01 Emergency Stop**

This message is displayed when the operator stops the Genset by pushing the stop button in automatic or test procedures.

➤ **E04 Generator Voltage Failure**

It occurs when, with engine running, the Genset voltage goes out of the programmed voltage and time limits.

ALARMS CODE TABLE			
Cod.	Description	Immediate Shutdown	Alarm On
A01	Temperature Alarm	Yes	Yes
A02	Oil Pressure Alarm	Yes	Yes
A03	Charger Alternator Failure Alarm	Yes	Yes
A04	Mechanical Failure	Yes	Yes
A05	Request for Maintenance	No	Yes
A06	Runaway Speed Alarm (over speed)	Yes	Yes
A07	Fuel Level	Prog (No)	Prog
A08	Low Water Level	Prog (Yes)	Prog
A09	Dirty Air Filter	Prog (Yes)	Prog
A10	Start Failure	Yes	Yes
A11	Min. Frequency	Yes	Yes
A12	Min. Battery Voltage		Yes
A13	Max. Battery Voltage		Yes
E01	Emergency Stopping On	Yes	Yes
E04	Generator Voltage Failure	Yes	Yes

TECHNICAL FEATURES	
Supply Circuit	
Battery Supply (US)	12 Vdc
Maximum Current Consumption	160mA (250mA with rs485)
Stand-by Current	110 mA (250mA with rs485)
Operating Range 12V	6.2 – 16.5 Vdc
Immunity Time for Micro breaking	~150 ms
Maximum Ripple	10%
Mains Voltage Control Circuit	
Rated Voltage (UE)	100-480 VAC
Operating Range	60 Hz
Generator Voltage Control Circuit	
Voltage Range	100-480 Vac
Operating Range	70-624 Vac
Started Engine Control Circuit	
Battery Charger Permanent Magnet Alternator	0-40 Vac
Battery Charger Energized Alternator	
Operating Range	0-40 Vdc
Adjustment Range	6-30 Vdc
Circuit Voltage	12 Vdc Battery
Output Relay Contacts	
Common Alarm Relay (Fault Relay)	1 NO / NC Contact (SPDT)

2. OPERATING AND SET-UP PROGRAMMING PROCEDURES

WARNING:

This section allows the internal program settings to be modified. Only GENMAC trained personnel are qualified to perform any alterations to the data stored in the HS control system. GENMAC can not be held responsible for personnel injury and any damage done to this or any other equipment. Changes performed by unauthorized personnel could result in loss of warranty.

2.1 CONTROLLER OPTION MENU

OPTION #	OPTION DESCRIPTION	RANGE	DEFAULT
OP 1	Under-Voltage Sensing Of Utility	160-230 Vac	200
OP 2	Over-Voltage Sensing Of Utility	253-345 Vac	265
OP 3	Time Delay Engine Start	0-120 Seconds	5
OP 4	Time Delay Emergency To Normal	0-240 Seconds	60
OP 5	Under-Voltage Sensing Of Emergency	160-230 Vac	200
OP 6	Over-Voltage Sensing Of Emergency	253-345 Vac	265
OP 7	Emergency Voltage Monitor Delay	1-180 Seconds	5
OP 8	Time Delay Utility To Emergency	1-180 Seconds	30
OP 9	Engine Cool down Timer	1-300 Seconds	120
OP 10	Not Applicable	0-60 Seconds	20
OP 11	No Load Plant Exerciser Time Interval Between Tests	1-7 Days	7
OP 12	Duration Of Exercise	1-30 Minutes	10
OP 13	Not Applicable	0-99 Minutes	25
OP 14	Not Applicable	0-30 Minutes	5

2.2 OPTION MODIFICATION PROCEDURE

To reach the parameters which can be modified by the user from the RESET position.

- Press and hold RESET button
- Press MEASURE button and hold for approx 5 seconds then let up . (The display will show the first option number --OP.1 --)

Pressing the MEASURE button scrolls through the Options. Stop on the option (OP.X) you are modifying, the stored value of the parameter is displayed for 3 seconds. If you push START during these 3 seconds, you will increase the variable (up to its maximum allowed value). If you push STOP during these 3 seconds, you will decrease the variable (down to its minimum allowed value). If you do not push any buttons and let the 3 seconds pass, you go back to the option number display. By pushing RESET you store this change and leave this procedure. If you do not push any buttons for 30 seconds the control panel leaves the procedure automatically and does not store any changes or updates.

How to gain admittance to the Set up parameters

This section allows the internal program settings to be modified. Only GENMAC trained personnel are qualified to perform any alterations to the data stored in the HS control system. GENMAC can not be held responsible for personnel injury and any damage done to this or any other equipment. Changes performed by unauthorized personnel could result in loss of warranty.

Set up parameters are protected by a code sequence (admittance Code). This sequence is as follows:

- Push and hold **RESET** button
- Push **START** button twice
- Push **STOP** button three times
- Push **MEASURE** button four times
- Release **RESET** button (the display will show **SET** message)
- Push **START** again

The display will first show “ **SEt**” press **START** one time and the display will show the number of the first setup “-01”. By pushing **RESET** you can store changes and exit this function.

The **MEASURE** button scrolls forward through the setup numbers. Choose the set up number to be modified. Press the **START** or **STOP** button once, the stored value of the set up is displayed for the 3 seconds. If you push **START** during these 3 seconds, you will increase the variable (up to its maximum allowed value) while pushing **STOP** you will decrease it (down to its minimum allowed value). If you do not push any buttons and let the 3 seconds pass the display reverts to the option number. By pushing **RESET** the modifications are stored and you leave this procedure. If you do not push any buttons for 30 seconds the control panel leaves the procedure automatically and no values are changed.

Controller Set Up Menu

SETUP#	SETUP DESCRIPTION	RANGE	DEFAULT	
			HS G/D	RGU
O1	GENERATOR FREQUENCY	0 (50 HZ), 1 (60HZ)	1	
O2	NOT APPLICABLE	0 (OFF) , 1 (ON)	1	
O3	REMOTE START	0(NORMAL) 1(EJP) 2(SCR) 3(EJP/T)	0	
O4	UTILITY METERING	0 (NORMAL), 1 (ALARM STOP), 2 (Disable Utility Metering = 2-WIRE ATS)	0	
O5	CRANK DISCONNECT SIGNAL (ALT OR GEN)	0 (DC ALTERNATOR), 1 (AC GENERATOR)	0	1
O6	CRANK DISCONNECT ALTERNATOR (Engine charger)	6-60V	15	1
O7	CRANK DISCONNECT GENERATOR (AC Generator)	5-200 VAC	10	10
O8	SHUTDOWN ALARM DELAY TIME	1-60 SECONDS	15	15
O9	STOP TIME IN MANUAL POSITION	1-30 SECONDS	20	20
10	CYCLE CRANK NUMBER OF STARTS	01-10	5	5
11	CYCLE CRANK LENGTH OF STARTS	1-30 SECONDS	8	10
12	CYCLE CRANK TIME BETWEEN STARTS	1-20 SECONDS	10	10
13	DELAY BETWEEN AN INTERRUPTED ATTEMPT TO START AND THE NEXT ONE	2-5 SECONDS	3	3
14	500 RPM UNDERSPEED SHUTDOWN DELAY (A03)	2-5 SECONDS	3	3
15	GENERATOR/UTILITY CONTACTOR CLOSURE DELAY TIME	0-10 (100 MILISECONDS INCREMENTS)	5	5
16	MAINTENANCE INTERVAL	10-250 HOURS	50	50
17	GLOW PLUG (DIESEL FUEL ONLY)	0(OFF) 1(N/A) 2(GLOW PLUG ENABLE)	0	2
18	NOT APPLICABLE	1-180 SECONDS	60	60
19	GLOW PLUG TIME	1-60 SECONDS	10	10
20	EXERCISE IN W/ EXT STOP ACTIVE	0(OFF) , 1(ON)	0	0
21	AUTO/TEST MODE DISABLE (THE CONTROLLER ONLY WORKS IN THE MANUAL OR RESET POSITION)	0(NORMAL) 1(SWITCH OFF – AUTO & TEST FUNCTIONS)	0	0
22	LOW FUEL LEVEL ALARM (A07)	0(OFF) 1(PRE ALARM) 2 (SHUTDOWN)	1	2

D= Diesel Units, G= Gaseous Units, HS = Home StandBy, RGU= Master RGU Series

Controller Set Up Menu continued

SETUP#	SETUP DESCRIPTION	RANGE	DEFAULT	
			HS G/D	RGU
23	SPARE ALARM INPUT / (A08)	0(OFF) 1(PRE ALARM) 2 (SHUTDOWN)	0	
24	SPARE ALARM INPUT / Dirty Air Filter Alarm (A09)	0(OFF) 1(PRE ALARM) 2 (SHUTDOWN)	2	0
25	REMOTE MOUNTED "E" STOP (E01)	0 (DISABLED), 1(ENABLED)	0	
26	ADDITIONAL DELAY FOR ALARM (A08) THE TIME STARTS AFTER THE ALARM IS ACTIVATED	0-120 SECONDS	0	0
27	NOT APPLICABLE / SERIAL ADDRESS FOR REMOTE CONTROL	01-32	1	1
28	FUEL SETUP CONFIGURATION	0(DIESEL) 1(GASEOUS) 2 N/A	1 / 0	0
29	ACTIVATE GASEOUS FUEL SOLENOID / Fault Relay	0 (ON), 1(OFF) / (0) Enable (1) GASEOUS FUEL SOLENOID	0	0
30	GASEOUS SOLENOID DELAY TIME	1-5 SECONDS	1	2
31	PRIMER TIME	1-10 SECONDS	2	5
32	NOT APPLICABLE	8	8	
33	NOT APPLICABLE	8	8	
34	OVER FREQUENCY (A06) SHUTDOWN (E04)	0 (ON), 1 (OFF)	0	
35	GENERATOR UNDER (E04) VOLTAGE SHUTDOWN	0 (ON) , 1 (OFF)	0	
36	TRANSFER TO NORMAL WHEN THE GENERATOR FAILS	0 (SWITCH TO UTILITY) 1 (WILL NOT TRANSFER)	0	
37	SINGLE PHASE OR THREE PHASE SELECTION	0 (1 PHASE), 1 (3 PHASE)	0	
38	GENERATOR UNDER VOLTAGE SHUTDOWN DELAY (E04)	15-240 SECONDS	10	
39	MINIMUM BATTERY VOLTAGE	7-12 VDC	9	
40	MAXIMUM BATTERY VOLTAGE	13-17 VDC	16	
41	UNDER FREQUENCY ALARM	20-60 HZ	57	
42	UNBALANCED UTILITY VOLTAGE PROTECTION	5-20% NOT APPLICABLE	15	

D= Diesel Units, G= Gaseous Units, HS = Home StandBy, RGU= Master RGU Series

3. ATS INFORMATION

Connections:

Te 803 Single Phase controller to Zenith Single or 3 Phase* ATS

ATS Interconnection diagram (Z)

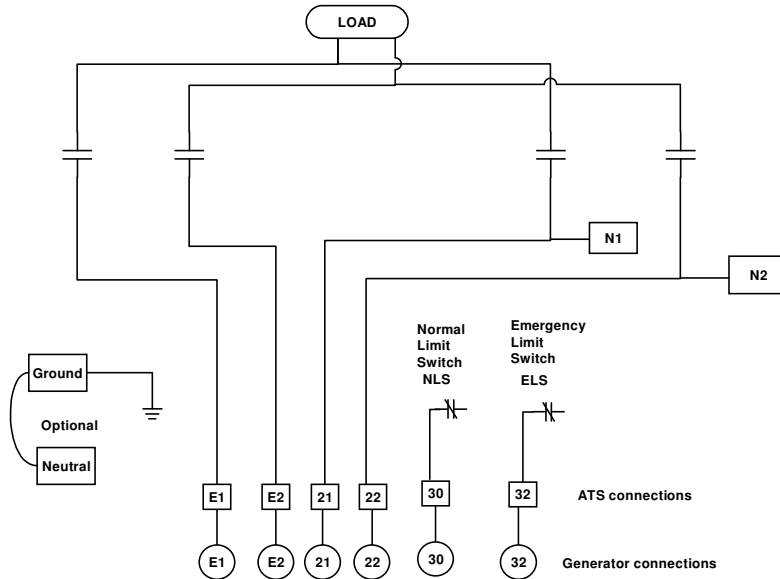

*Note

In the case of 3 Phase ATS - the wiring for the third phase is not connected

Te 803 Single Phase controller to Cutler Hammer Single Phase ATS

ATS Interconnection diagram (CH)

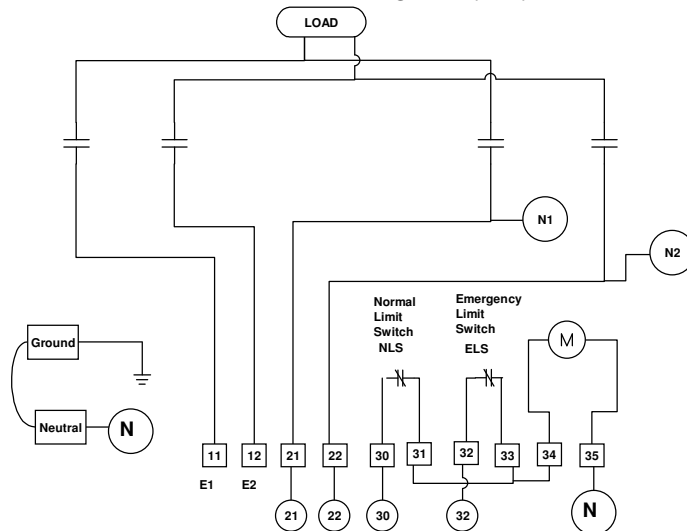

Note: Jumper is required between ATS pins 31, 33, and 34. Pin 35 must be connected to neutral.

How to wire the HS Single Phase (Te 803) Controller to Interface with an ATS containing Logic.

Standard HS & MASTER units are not configured from the factory for use with an ATS containing logic. The following instructions are to be followed when configuring the Te 803 for use with a Standard 2 wire Automatic Transfer Switch (ATS).

If **Normally Closed** contacts are available on the Logic ATS: For Normal ATS operation connect one wire to Ground on the Controller and the other wire to Pin 5 on the controller. This signal is called "System Disable". When the pin is shorted to ground the system will not start in **AUTO**. When the contacts on the ATS open the system will start and run. When Pin 5 is again attached to ground the system will display E03, (Remote Stopping) and the engine will continue to run for the time specified in (OP09) the Cool down Timer. Then the engine will shut off and be ready for the next time the contacts are open. If exercising independent of the ATS is required then change Setup # 20 to 1. This will cause the system to exercise the min. set in OP 12 and every OP 11 number of days.

IF **Normally Open** Contacts are available. Change Setup # 4 to equal 2. This disables the internal Mains Monitor function. Press **AUTO** the generator will start and run when terminal 6 on the controller is connected to ground (External Start) and Stop when the connection to ground is removed. The exercise function will perform without any additional changes. See the Setup Modification section for how to modify the Set-Up parameters.