



DEEP SEA ELECTRONICS PLC

DSE3210 CONTROLLER OPERATORS MANUAL

Document number 057-153

Author: Allan Jones



Deep Sea Electronics Plc
Highfield House
Hunmanby
North Yorkshire
YO14 0PH
ENGLAND

Sales Tel: +44 (0) 1723 890099
Sales Fax: +44 (0) 1723 893303

E-mail: support@deepseapl.com
Website: www.deepseapl.com

DSE Model DSE3210 Operators Manual

© Deep Sea Electronics Plc

All rights reserved. No part of this publication may be reproduced in any material form (including photocopying or storing in any medium by electronic means or other) without the written permission of the copyright holder except in accordance with the provisions of the Copyright, Designs and Patents Act 1988.

Applications for the copyright holder's written permission to reproduce any part of this publication should be addressed to Deep Sea Electronics Plc at the address above.

The DSE logo is a UK registered trademark of Deep Sea Electronics PLC.

Any reference to trademarked product names used within this publication is owned by their respective companies.

Deep Sea Electronics Plc reserves the right to change the contents of this document without prior notice.

Amendments since last publication

Issue no.	Comments
1	First Release

Clarification of notation used within this publication.

 **NOTE:**

Highlights an essential element of a procedure to ensure correctness.

 **CAUTION!**

Indicates a procedure or practice, which, if not strictly observed, could result in damage or destruction of equipment.

 **WARNING!**

Indicates a procedure or practice, which could result in injury to personnel or loss of life if not followed correctly.

TABLE OF CONTENTS

Section	Page
1 BIBLIOGRAPHY	5
1.1 INSTALLATION INSTRUCTIONS	5
1.2 MANUALS.....	5
2 INTRODUCTION	5
3 SPECIFICATIONS.....	6
3.1 PART NUMBERING	6
3.2 TERMINAL SPECIFICATION	6
3.3 POWER SUPPLY REQUIREMENTS	6
3.4 INPUTS	7
3.4.1 DIGITAL INPUTS.....	7
3.4.2 FREQUENCY SENSING INPUT HZ , RPM.....	7
3.4.3 MAGNETIC PICKUP.....	7
3.5 CHARGE FAIL INPUT/OUTPUT	8
3.6 OUTPUTS	8
3.6.1 FUEL & CRANK.....	8
3.6.2 PRE-HEAT/CONFIGURABLE	8
3.7 PC CONFIGURATION	9
3.8 DIMENSIONS AND MOUNTING	10
3.8.1 DIMENSIONS	10
3.8.2 PANEL CUTOUT	10
3.8.3 WEIGHT.....	10
3.8.4 FIXING CLIPS.....	10
3.8.5 OPTIONAL SILICON SEALING GASKET	10
3.9 APPLICABLE STANDARDS	11
3.9.1 ENCLOSURE CLASSIFICATIONS.....	12
IP CLASSIFICATIONS.....	12
NEMA CLASSIFICATIONS.....	13
4 INSTALLATION.....	14
4.1 USER CONNECTIONS.....	14
4.2 TERMINAL DESCRIPTION	15
4.2.1 DC SUPPLY, FUEL AND START OUTPUTS.....	15
4.2.2 GENERATOR VOLTAGE SENSING OR MAGNETIC PICKUP	15
4.2.3 DIGITAL INPUTS.....	15
4.3 TYPICAL WIRING DIAGRAM.....	16
4.4 DESCRIPTION OF CONTROLS	17
4.4.1 DSE3210 KEYSWITCH CONTROLLER	17
4.4.2 QUICKSTART GUIDE	18
CONTROLS.....	18
5 OPERATION.....	19
5.1 AUTOMATIC MODE OF OPERATION.....	19
5.1.1 WAITING IN AUTO MODE	19
5.1.2 STARTING SEQUENCE.....	19
5.1.3 ENGINE RUNNING.....	20
5.1.4 STOPPING SEQUENCE	20
5.2 MANUAL OPERATION.....	21
5.2.1 WAITING IN MANUAL MODE	21
5.2.2 STARTING SEQUENCE.....	21
5.2.3 ENGINE RUNNING.....	21
5.2.4 STOPPING SEQUENCE	21
6 PROTECTIONS.....	22
6.1 SHUTDOWN	22
6.2 WARNING.....	22
7 MODULE DISPLAY.....	23

7.1	TIMER ICON	23
7.2	STOPPED ICON	23
7.3	RUNNING ICON.....	23
7.4	USB ICON	23
7.5	MEMORY CORRUPTION.....	23
7.6	BACKLIGHT.....	23
7.7	FAULT ICONS.....	24
8	COMMISSIONING	25
8.1	PRE-COMMISSIONING.....	25
9	FAULT FINDING	26
10	MAINTENANCE, SPARES, REPAIR AND SERVICING.....	28
11	MAINTENANCE, SPARES, REPAIR AND SERVICING.....	28
11.1	PURCHASING ADDITIONAL CONNECTOR PLUGS FROM DSE.....	28
11.2	PURCHASING ADDITIONAL FIXING CLIPS FROM DSE	28
11.3	PURCHASING SEALING GASKET FROM DSE	28
12	WARRANTY.....	29
13	DISPOSAL	29
13.1	WEEE (WASTE ELECTRICAL AND ELECTRONIC EQUIPMENT).....	29
13.2	ROHS (RESTRICTION OF HAZARDOUS SUBSTANCES)	29
14	APPENDIX	30
14.1	COMMUNICATIONS OPTION CONNECTIONS	30
14.1.1	DESCRIPTION.....	30
14.1.2	PC TO CONTROLLER (DIRECT) CONNECTION	30

1 BIBLIOGRAPHY

This document refers to and is referred to by the following DSE publications which can be obtained from the DSE website www.deepseapl.com

1.1 INSTALLATION INSTRUCTIONS

Installation instructions are supplied with the product in the box and are intended as a 'quick start' guide only.

DSE PART	DESCRIPTION
053-133	DSE3210 Installation Instruction

1.2 MANUALS

DSE PART	DESCRIPTION
057-152	DSE3210 Configuration Suite Software Manual

2 INTRODUCTION

This document details the installation and operation requirements of the DSE3210 controller is part of the DSEgenset ® range of products.

The manual forms part of the product and should be kept for the entire life of the product. If the product is passed or supplied to another party, ensure that this document is passed to them for reference purposes.

This is not a *controlled document*. You will not be automatically informed of updates. Any future updates of this document will be included on the DSE website at www.deepseapl.com

The DSE3210 controller is used to start and stop a engine and indicate fault conditions. The DSE3210 will automatically shut the engine down upon fault.

Using a PC and the 3210 series configuration software allows alteration of selected operational sequences, timers and alarm trips.

A robust plastic case designed for front panel mounting houses the module. Connections are via locking plug and sockets.

3 SPECIFICATIONS

3.1 PART NUMBERING

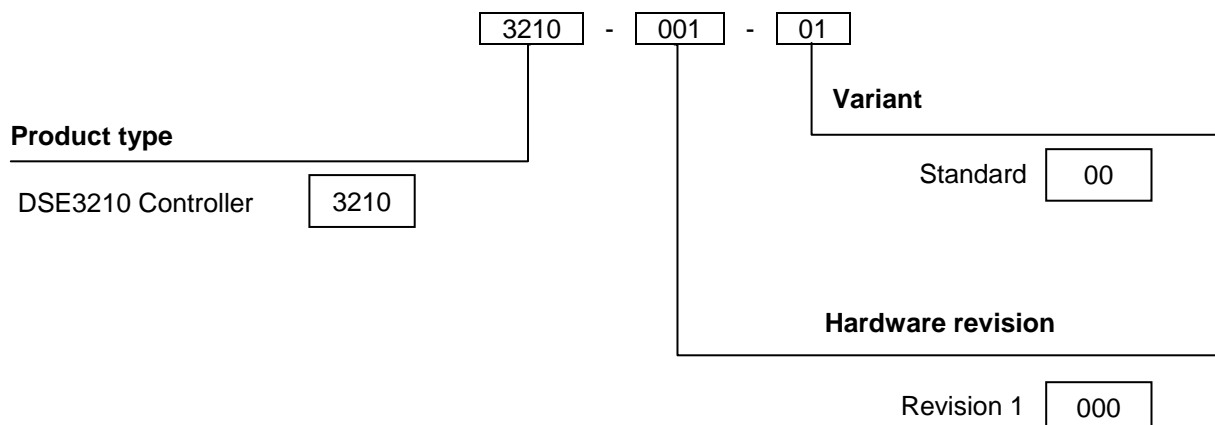

At the time of this document production, there are no variants of DSE3210 product.

3.2 TERMINAL SPECIFICATION

Connection type	Two part connector. <ul style="list-style-type: none"> • Male part fitted to module • Female part supplied in module packing case - Screw terminal, rising clamp, no internal spring. 	 <p>Example showing cable entry and screw terminals of a 10 way connector</p>
-----------------	---	--

3.3 POWER SUPPLY REQUIREMENTS

Minimum supply voltage	8V continuous
Cranking dropouts	Able to survive 0V for 50mS providing the supply was at least 10V before the dropout and recovers to 5V afterwards. This is more than sufficient to allow the controller to operate during engine cranking where the battery supply often falls as low as 4V (on a 12V system!) This is achieved without the need for internal batteries or other external requirements.
Maximum supply voltage	35V continuous (60V protection for surges)
Reverse polarity protection	-35V continuous
Maximum operating current	27mA at 24V 26mA at 12V
Maximum standby current	21mA at 24V 20mA at 12V

3.4 INPUTS

3.4.1 DIGITAL INPUTS

Number	6
Arrangement	Contact between terminal and ground
Low level threshold	2.1V minimum
High level threshold	6.6V maximum
Maximum input voltage	+50V DC with respect to plant supply negative
Minimum input voltage	-24V DC with respect to plant supply negative
Contact wetting current	2.5mA typical
Open circuit voltage	12V typical

3.4.2 FREQUENCY SENSING INPUT HZ , RPM

Measurement type	Frequency
Input Impedance	900k Ω L-N
Phase to Neutral	15V to 333V AC (max)
Minimum frequency	3.5Hz
Maximum frequency	75.0Hz
Frequency resolution	0.1Hz
Frequency accuracy	± 0.2 Hz

3.4.3 MAGNETIC PICKUP

Type	Differential input
Minimum voltage	0.6V RMS
Max common mode voltage	± 2 V
Maximum frequency	10,000Hz
Resolution	6.25 RPM
Accuracy	± 25 RPM

NOTE : DSE can supply a suitable magnetic pickup device, available in two body thread lengths :
DSE Part number 020-012 - Magnetic Pickup probe 5/8 UNF 2½" thread length
DSE Part number 020-013 - Magnetic Pickup probe 5/8 UNF 4" thread length

Magnetic Pickup devices can often be 'shared' between two or more devices. For example, one device can often supply the signal to both the DSE3210 speed switch and the engine governor. The possibility of this depends upon the amount of current that the magnetic pickup can supply.

3.5 CHARGE FAIL INPUT/OUTPUT

Minimum voltage	0V
Maximum voltage	35V (plant supply)
Resolution	0.2V
Accuracy	±1% of max measured voltage (±0.35V)
Excitation	Active circuit constant power output
Output Power	2.5W Nominal @12V and 24V
Current at 12V	210mA
Current at 24V	104mA

The charge fail input is actually a combined input and output.

Whenever the generator is required to run, the terminal provides excitation current to the charge alternator field winding.

When the charge alternator is correctly charging the battery, the voltage of the terminal is close to the plant battery supply voltage. In a failed charge situation, the voltage of this terminal is pulled down to a low voltage. It is this drop in voltage that triggers the *charge failure* alarm. The level at which this operates and whether this triggers a warning or shutdown alarm is configurable using the DSE Config Suite Lite Software.

3.6 OUTPUTS

3.6.1 FUEL & CRANK



Number	2
Type	Negative switching Fuel and Crank outputs.
Rating	1.2A resistive @ 35V

3.6.2 PRE-HEAT/CONFIGURABLE

Number	1
Type	Negative switching Fully configurable
Rating	1.2A resistive @ 35V

3.7 PC CONFIGURATION

This configuration cable is the same as normally used between a PC and a USB printer.

	DESCRIPTION	CABLE SIZE	NOTES
	Socket for connection to PC with DSE Configuration Suite PC software.	0.5mm ² AWG 20	This is a standard USB type A to type B cable. 

NOTE:- The USB connection cable between the PC and the 3000 series module must not be extended beyond 5m (5yds). For distances over 5m, it is possible to use a third party USB extender. Typically, they extend USB up to 50m (yds). The supply and support of this type of equipment is outside the scope of Deep Sea Electronics PLC.

CAUTION!: Care must be taken not to overload the PCs USB system by connecting more than the recommended number of USB devices to the PC. For further information, consult your PC supplier.

CAUTION!: This socket must not be used for any other purpose.

3.8 DIMENSIONS AND MOUNTING

3.8.1 DIMENSIONS

99 mm x 79 mm x 40 mm
(3.9" x 3.1" x 1.6")

3.8.2 PANEL CUTOUT

80 mm x 68 mm
(3.2" x 2.7")

3.8.3 WEIGHT

89 g
(0.089kg)

3.8.4 FIXING CLIPS

The module is held into the panel fascia using the supplied fixing clips.

- Withdraw the fixing clip screw (turn anticlockwise) until only the pointed end is protruding from the clip.
- Insert the three 'prongs' of the fixing clip into the slots in the side of the module case.
- Pull the fixing clip backwards (towards the back of the module) ensuring all three prongs of the clip are inside their allotted slots.
- Turn the fixing clip screws clockwise until they make contact with the panel fascia.
- Turn the screws a little more to secure the module into the panel fascia. Care should be taken not to over tighten the fixing clip screws.

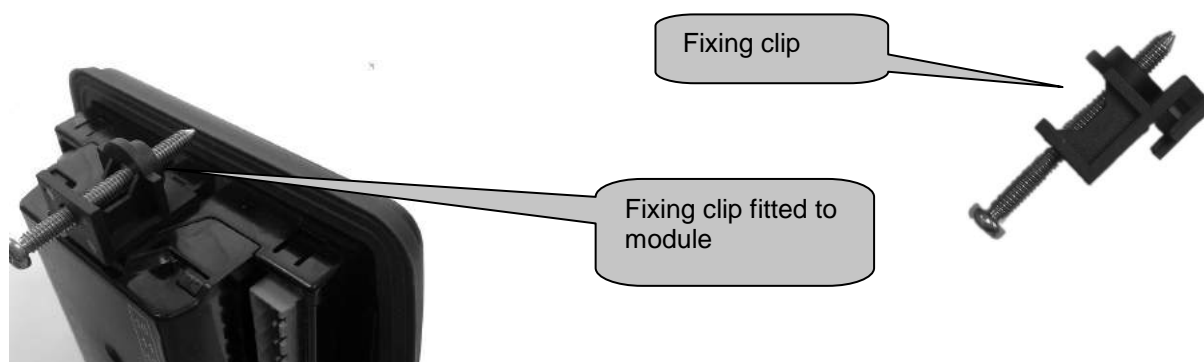

NOTE:- In conditions of excessive vibration, mount the panel on suitable anti-vibration mountings.

3.8.5 OPTIONAL SILICON SEALING GASKET

The optional silicon gasket provides improved sealing between the 3000 series module and the panel fascia.

The gasket is fitted to the module before installation into the panel fascia.

Take care to ensure the gasket is correctly fitted to the module to maintain the integrity of the seal.

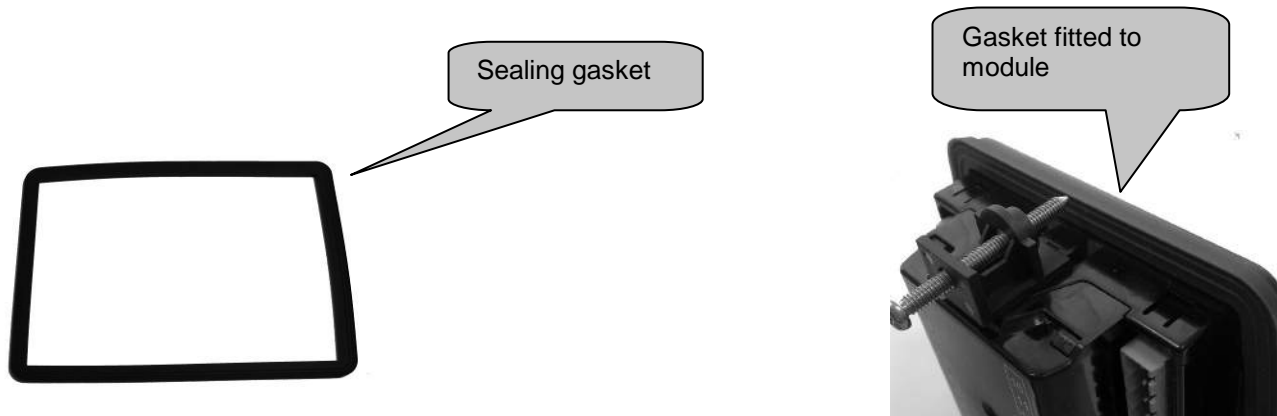

3.9 APPLICABLE STANDARDS

BS 4884-1	This document conforms to BS4884-1 1992 Specification for presentation of essential information.
BS 4884-2	This document conforms to BS4884-2 1993 Guide to content
BS 4884-3	This document conforms to BS4884-3 1993 Guide to presentation
BS EN 60068-2-1 (Minimum temperature)	-30°C (-22°F)
BS EN 60068-2-2 (Maximum temperature)	+70°C (158°F)
BS EN 60950	Safety of information technology equipment, including electrical business equipment
BS EN 61000-6-2	EMC Generic Immunity Standard (Industrial)
BS EN 61000-6-4	EMC Generic Emission Standard (Industrial)
BS EN 60529 (Degrees of protection provided by enclosures) (see overleaf)	IP 54 (front of controller when installed into the control panel with the optional sealing gasket). IP41 (front of controller when installed into the control panel WITHOUT being sealed to the panel)
UL508 NEMA rating (Approximate) (see overleaf)	2 (Front of module when installed into the control panel with the optional sealing gasket). 2 (Front of controller when installed into the control panel WITHOUT being sealed to the panel)
IEEE C37.2 (Standard Electrical Power System Device Function Numbers and Contact Designations)	Under the scope of IEEE 37.2, <i>function numbers can also be used to represent functions in microprocessor devices and software programs.</i> As the controller is configurable by the generator OEM, the functions covered by the controller will vary. Under the controller's factory configuration, the device numbers included within the controller are : 2 – Time delay starting or closing relay 6 – Starting circuit breaker 30 – annunciator relay 54 – turning gear engaging device 62 – time delay stopping or opening relay 63 – pressure switch 74– alarm relay 81 – frequency relay 86 – lockout relay

In line with our policy of continual development, Deep Sea Electronics, reserve the right to change specification without notice.

3.9.1 ENCLOSURE CLASSIFICATIONS

IP CLASSIFICATIONS

DSE3210 BS EN 60529 Degrees of protection provided by enclosures

IP54 Front of controller (suitable grease should be applied to terminals if exposed to a harsh environment (With Gasket)

IP41 (front of controller when controller is installed into the control panel WITHOUT being sealed to the panel) (Without gasket)

First Digit	Second Digit
Protection against contact and ingress of solid objects 0 No protection	Protection against ingress of water 0 No protection
1 Protected against ingress solid objects with a diameter of more than 50 mm. No protection against deliberate access, e.g. with a hand, but large surfaces of the body are prevented from approach.	1 Protection against dripping water falling vertically. No harmful effect must be produced (vertically falling drops).
2 Protected against penetration by solid objects with a diameter of more than 12 mm. Fingers or similar objects prevented from approach.	2 Protection against dripping water falling vertically. There must be no harmful effect when the equipment (enclosure) is tilted at an angle up to 15° from its normal position (drops falling at an angle).
3 Protected against ingress of solid objects with a diameter of more than 2.5 mm. Tools, wires etc. with a thickness of more than 2.5 mm are prevented from approach.	3 Protection against water falling at any angle up to 60° from the vertical. There must be no harmful effect (spray water).
4 Protected against ingress of solid objects with a diameter of more than 1 mm. Tools, wires etc. with a thickness of more than 1 mm are prevented from approach.	4 Protection against water splashed against the equipment (enclosure) from any direction. There must be no harmful effect (splashing water).
5 Protected against harmful dust deposits. Ingress of dust is not totally prevented but the dust must not enter in sufficient quantity to interface with satisfactory operation of the equipment. Complete protection against contact.	5 Protection against water projected from a nozzle against the equipment (enclosure) from any direction. There must be no harmful effect (water jet).
6 Protection against ingress of dust (dust tight). Complete protection against contact.	6 Protection against heavy seas or powerful water jets. Water must not enter the equipment (enclosure) in harmful quantities (splashing over).

NEMA CLASSIFICATIONS

DSE3210 NEMA Rating (Approximate)

2 Front of controller (suitable grease should be applied to terminals if exposed to a harsh environment) (With gasket)
 2 (front of controller when controller is installed into the control panel WITHOUT being sealed to the panel) (Without Gasket)

 **NOTE: - There is no direct equivalence between IP / NEMA ratings. IP figures shown are approximate only.**

1 IP30	Provides a degree of protection against contact with the enclosure equipment and against a limited amount of falling dirt.
2 IP31	Provides a degree of protection against limited amounts of falling water and dirt.
3 IP64	Provides a degree of protection against windblown dust, rain and sleet; undamaged by the formation of ice on the enclosure.
3R IP32	Provides a degree of protection against rain and sleet.; undamaged by the formation of ice on the enclosure.
4 (X) IP66	Provides a degree of protection against splashing water, windblown dust and rain, hose directed water; undamaged by the formation of ice on the enclosure. (Resist corrosion).
12/12K IP65	Provides a degree of protection against dust, falling dirt and dripping non corrosive liquids.
13 IP65	Provides a degree of protection against dust and spraying of water, oil and non corrosive coolants.

4 INSTALLATION

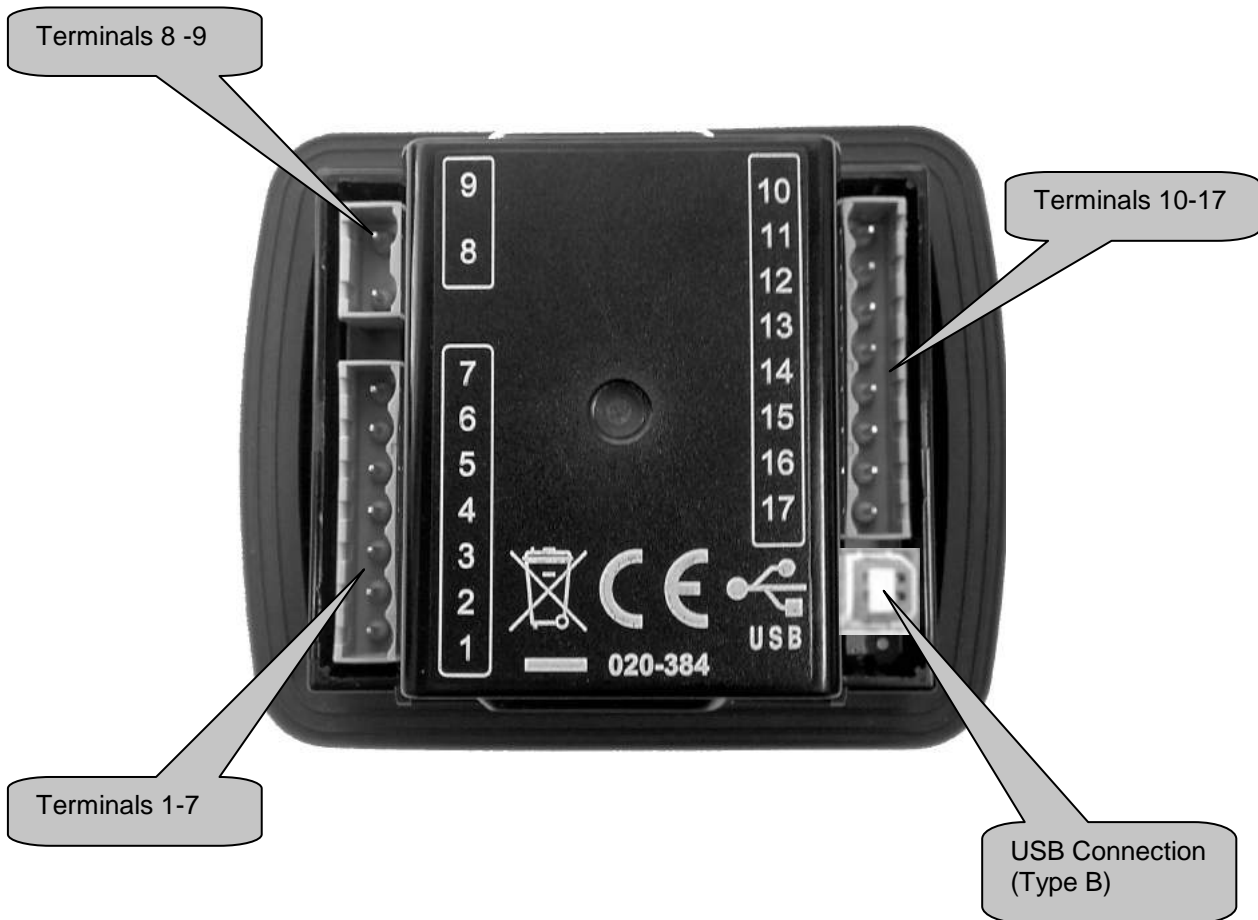

The DSE3210 controller is designed to be mounted on the panel fascia. For dimension and mounting details, see the section entitled *Specification, Dimension and mounting* elsewhere in this document.

4.1 USER CONNECTIONS





4.2 TERMINAL DESCRIPTION

4.2.1 DC SUPPLY, FUEL AND START OUTPUTS

	PIN No	DESCRIPTION	CABLE SIZE	NOTES
	1	DC Plant Supply Input (Negative)	2.5mm ² AWG 13	
	2	DC Plant Supply Input (Positive)	2.5 mm ² AWG 13	(Recommended Maximum Fuse 15A anti-surge) Supplies the module (2A anti-surge requirement) and all output relays
	3	Output A (FUEL)	1.0mm ² AWG 18	Plant Supply Positive from terminal 2. 3 Amp rated.
	4	Output B (START)	1.0mm ² AWG 18	Plant Supply Positive from terminal 2. 3 Amp rated.
	5	Output C	1.0mm ² AWG 18	Plant Supply Positive from terminal 2. 3 Amp rated.
	6	Output D	1.0mm ² AWG 18	Plant Supply Positive from terminal 2. 3 Amp rated.
	7	Charge fail / excite	2.5mm ² AWG 13	Do not connect to ground (battery negative). If charge alternator is not fitted, leave this terminal disconnected.

4.2.2 GENERATOR VOLTAGE SENSING OR MAGNETIC PICKUP

	PIN No	DESCRIPTION	CABLE SIZE	NOTES
	8	Generator Neutral (N) input	1.0mm ² AWG 18	Connect to generator Neutral terminal (AC)
	9	Generator L1 (U) voltage monitoring	1.0mm ² AWG 18	Connect to generator L1 (U) output (AC) (Recommend 2A fuse)
	8	Magnetic pickup Negative	0.5mm ² AWG 20	Connect to Magnetic Pickup device
	9	Magnetic pickup Positive	0.5mm ² AWG 20	Connect to Magnetic Pickup device

4.2.3 DIGITAL INPUTS

	PIN No	DESCRIPTION	CABLE SIZE	NOTES
	12	Configurable digital input A	0.5mm ² AWG 20	Switch to negative
	13	Configurable digital input B	0.5mm ² AWG 20	Switch to negative
	14	Configurable digital input C	0.5mm ² AWG 20	Switch to negative
	15	Configurable digital input D	0.5mm ² AWG 20	Switch to negative
	16	Configurable digital input E	0.5mm ² AWG 20	Switch to negative
	17	Configurable digital input F	0.5mm ² AWG 20	Switch to negative

 **NOTE:** - If you use PTFE insulating tape on the Oil pressure or Temperature switch thread when using earth return switches, ensure you do not insulate the entire thread, as this will prevent the switch body from being earthed via the engine block.

 **NOTE:-** Screened cable must be used for connecting the Magnetic Pickup, ensuring that the screen is earthed at one end ONLY other wise the cable will act as an aerial.

4.3 TYPICAL WIRING DIAGRAM

As every system has different requirements, these diagrams show only a TYPICAL system and do not intend to show a complete system.

Further wiring suggestions are available in the following DSE publications, available at www.deepseapl.com to website members.

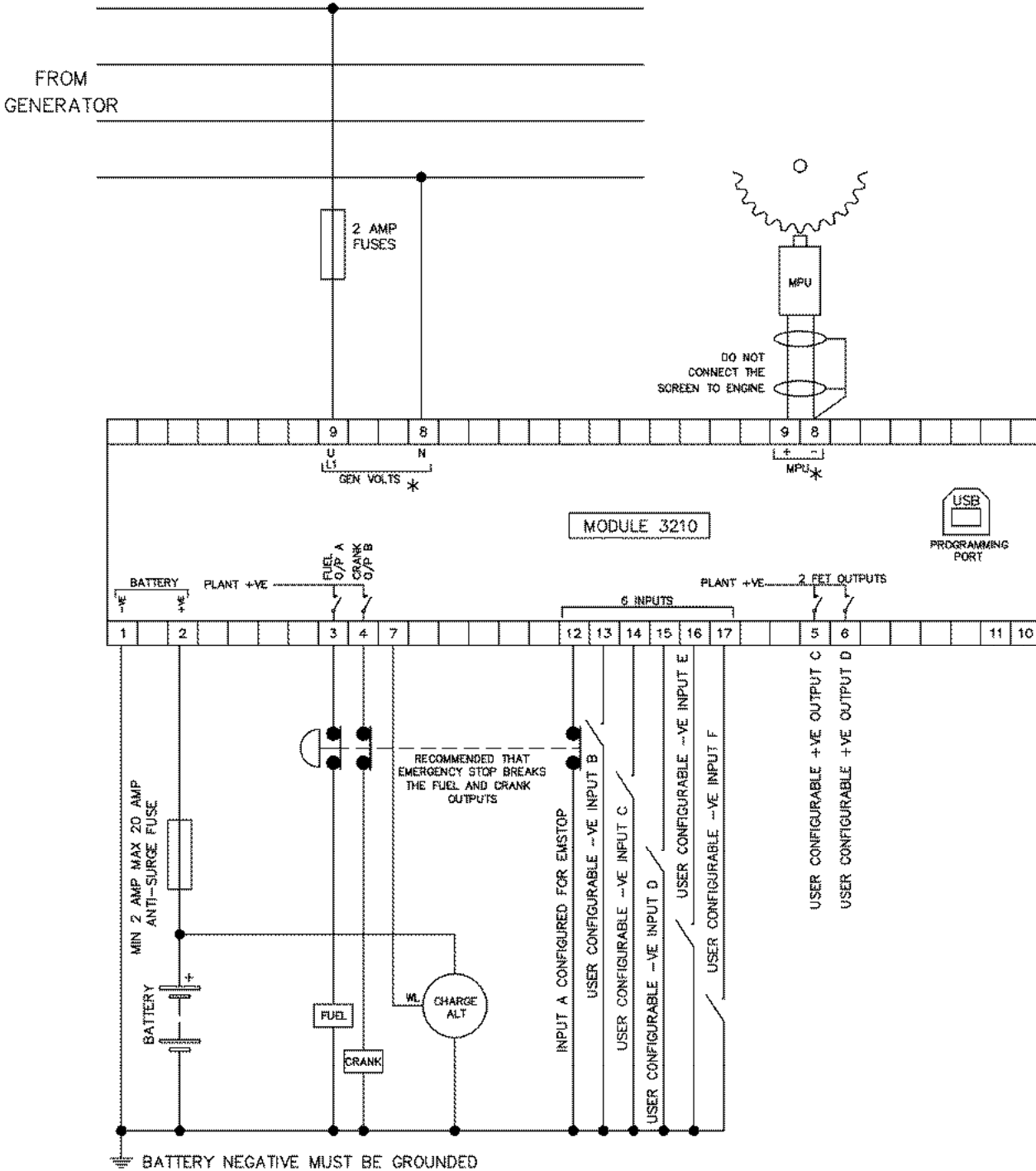

* NOTE. CONNECT EITHER MPU OR AC VOLTS FOR SPEED REFERENCE

4.4 DESCRIPTION OF CONTROLS

The following section details the function and meaning of the various controls on the controller.

4.4.1 DSE3210 KEYSWITCH CONTROLLER

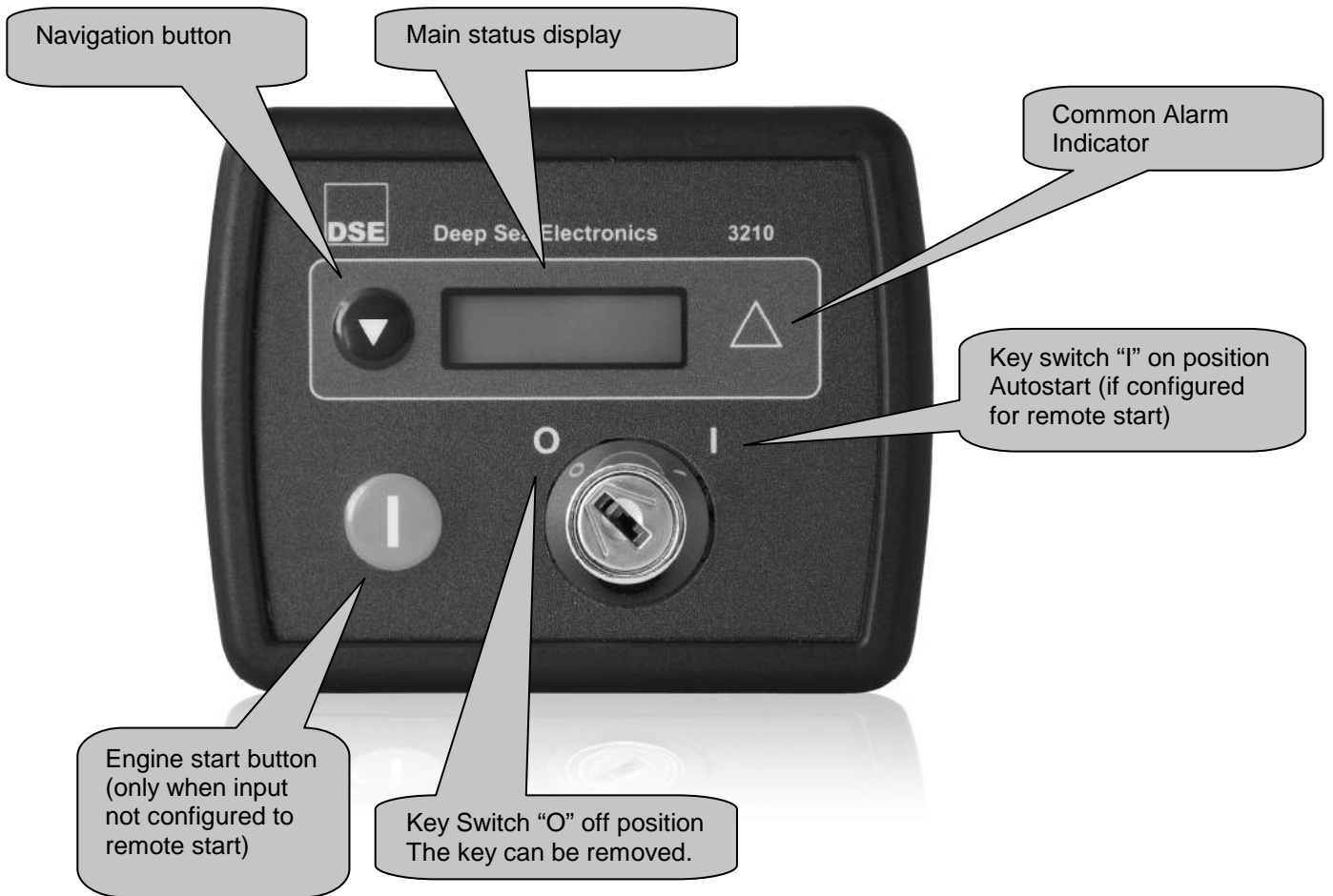

4.4.2 QUICKSTART GUIDE



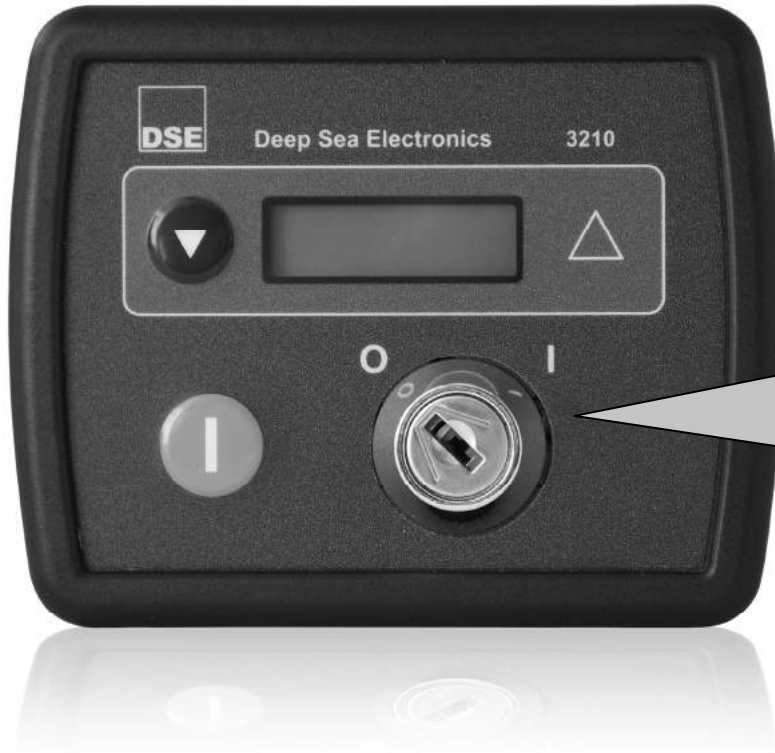

This section provides a quick start guide to the controller's operation



Insert Key and turn to position I

...Then, press the Start button to crank the engine. Depending upon module configuration, two presses may be required.

CONTROLS

<p>Stop /Reset This key switch position places the module into its Stop/Reset mode. This will clear any alarm conditions for which the triggering criteria have been removed. If the engine is running and the key switch is placed in Stop mode, the module will automatically de-energises the fuel output and the engine comes to a standstill. Should a remote start signal be present while operating in this mode, a remote start will not occur.</p>	
<p>Run This key switch position places the module into its RUN MODE. If the module has no input configured for a remote start signal this will place the module in the 'Manual' mode. The pre-heat output will become active for the duration of the set time once placed in this position. If the module has an input configured for remote start signal this will place the module in the 'Automatic' mode. To start the engine the input for remote start signal must be activated.</p>	
<p>Start Pressing this button in RUN MODE  with no remote start signal configured the engine will start and run.</p>	

NOTE:- For further details, see the section entitled 'OPERATION' elsewhere in this manual.

5 OPERATION

5.1 AUTOMATIC MODE OF OPERATION

 **NOTE:-** The user configurable digital input must be configured to *remote start* for this mode of operation.

Activate auto mode by turning the key switch to the  position.

Auto mode will allow the generator to operate fully automatically, starting and stopping as required with no user intervention.

 **NOTE:-** If started in auto mode the module remains in auto mode until it is turned off.

5.1.1 WAITING IN AUTO MODE

If a starting request is made, the starting sequence will begin.
Starting requests can be from the following sources:

- Activation of an auxiliary input that has been configured to *remote start*

5.1.2 STARTING SEQUENCE

If the engine fails to fire during this cranking attempt then the starter motor is disengaged for the *crank rest* duration after which the next start attempt is made. Should this sequence continue beyond the set number of attempts, the start sequence will be terminated and the display shows  **Fail to Start**.

When the engine fires, the starter motor is disengaged. Speed detection is factory configured to be derived from the main alternator output frequency but can additionally be measured from a Magnetic Pickup mounted on the flywheel (Selected by PC using the 3000 series configuration software).

Additionally, rising oil pressure can be used to disconnect the starter motor (but cannot detect underspeed or overspeed).

After the starter motor has disengaged, the *Safety On* timer activates, allowing Oil Pressure, High Engine Temperature, Under-speed, Charge Fail and any delayed Auxiliary fault inputs to stabilise without triggering the fault.

5.1.3 ENGINE RUNNING

Once the engine is running and all starting timers have expired, the animated  icon is displayed.

DSE3210 - The generator will be placed on load if configured to do so.

▲NOTE:-The load transfer signal remains inactive until the Oil Pressure has risen. This prevents excessive wear on the engine.

If all start requests are removed, the *stopping sequence* will begin.

5.1.4 STOPPING SEQUENCE

The *return delay* timer operates to ensure that the starting request has been permanently removed and isn't just a short term removal. Should another start request be made during the cooling down period, the set will return on load.

If there are no starting requests at the end of the *return delay* timer, the load is removed from the generator to the mains supply and the *cooling* timer is initiated.

The *cooling* timer allows the set to run off load and cool sufficiently before being stopped. This is particularly important where turbo chargers are fitted to the engine.

After the *cooling* timer has expired, the set is stopped.

5.2 MANUAL OPERATION

 **NOTE:-** The user configurable digital input must **NOT** be configured to remote start for this mode of operation.

Manual mode allows the operator to start and stop the set manually. Manual mode is active when the key switch is turned to the  position.

As soon as the key switch is in the  position, the Fuel Relay is energised and the Pre Heat Relay if configured will become energised for the configured time.

5.2.1 WAITING IN MANUAL MODE

To begin the starting sequence, press the  button, the start sequence begins immediately.

 **NOTE:-** If started in manual mode the module remains in manual mode until it is turned off.

5.2.2 STARTING SEQUENCE

The engine will start to crank.

If the engine fails to fire during this cranking attempt then the starter motor is disengaged for the *crank rest* duration after which the next start attempt is made. Should this sequence continue beyond the set number of attempts, the start sequence will be terminated and the  **ALARM CONDITION** LED will start flashing. LED will start flashing.

When the engine fires, the starter motor is disengaged. Speed detection is factory configured to the customer's specification upon ordering but can be changed using the DSE Configuration Suite PC Software in conjunction with the USB Interface.

Additionally, rising oil pressure can be used to disconnect the starter motor (but cannot detect underspeed or overspeed).

After the starter motor has disengaged, the *Safety On* timer activates, allowing Oil Pressure, High Engine Temperature, Under-speed, Charge Fail and any delayed Auxiliary fault inputs to stabilise without triggering the fault.

5.2.3 ENGINE RUNNING

There is no indication on the module to be depicted if the engine is running.

If the key switch is turned to the  position, the *stopping sequence* will begin.

5.2.4 STOPPING SEQUENCE

As soon as the key switch is turned to the  position, the engine will stop instantly.

6 PROTECTIONS

When an alarm is present, the Common alarm LED will flash.

The LCD display will show an icon to indicate the failure.

6.1 SHUTDOWN

The common alarm LED indicates a shutdown alarm. Shutdowns are critical alarm conditions that stop the engine and draw the operator's attention to an undesirable condition.

Shutdown alarms are latching. The fault must be removed and the key switch turned to the  position to reset the module.

6.2 WARNING

Warnings are non-critical alarm conditions and do not affect the operation of the generator system, they serve to draw the operators attention to an undesirable condition.

Warning alarms are self-resetting when the fault condition is removed. The icon will appear steady in the display.

7 MODULE DISPLAY

7.1 TIMER ICON

When the module is controlling the engine (starting and stopping) an animated timer icon will be displayed in the icon area to indicate that a timer is active, for example cranking time, crank rest etc.



7.2 STOPPED ICON

When there are no alarms present, an icon will be displayed to indicate the engine is stopped and what mode the unit is in.



Stop
mode



Auto
mode



Manual
mode

The hand is only displayed when the 'arming options' is enabled, otherwise the engine starts when entering the manual mode.

7.3 RUNNING ICON

When there are no alarms present, an animated icon is displayed to indicate the engine is running :



7.4 USB ICON

When a USB connection is made to the module the USB icon is displayed :

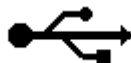

7.5 MEMORY CORRUPTION

















If either the config file or engine file becomes corrupted the unit will display the following icon :



7.6 BACKLIGHT

The backlight will be on if the unit has sufficient voltage on the power connection while the unit is turned on, unless the unit is cranking for which the backlight will be turned off.





7.7 FAULT ICONS

ICON	DESCRIPTION	
	AUXILIARY INPUTS	Auxiliary inputs can be user configured and will display the message as written by the user.
	FAIL TO START	The engine has not fired after the preset number of start attempts
	FAIL TO STOP	The module has detected a condition that indicates that the engine is running when it has been instructed to stop. NOTE:- 'Fail to Stop' could indicate a faulty oil pressure sensor - If engine is at rest check oil sensor wiring and configuration.
	LOW OIL PRESSURE	The module detects that the engine oil pressure has fallen below the low oil pressure pre-alarm setting level after the <i>Safety On</i> timer has expired.
	ENGINE HIGH TEMPERATURE	The module detects that the engine coolant temperature has exceeded the high engine temperature pre-alarm setting level after the <i>Safety On</i> timer has expired.
	UNDERSPEED	The engine speed has fallen below the underspeed pre alarm setting
	OVERSPEED	The engine speed has risen above the overspeed pre alarm setting
	CHARGE FAILURE	The auxiliary charge alternator voltage is low as measured from the W/L terminal.
	LOW FUEL LEVEL	The level detected by the fuel level sensor is below the low fuel level setting.
	BATTERY UNDER VOLTAGE / BATTERY OVER VOLTAGE	The DC supply has fallen below or risen above the low/high volts setting level.
	GENERATOR UNDER VOLTAGE	The generator output voltage has fallen below the pre-set pre-alarm setting after the <i>Safety On</i> timer has expired.
	GENERATOR OVER VOLTAGE	The generator output voltage has risen above the pre-set pre-alarm setting.
	GENERATOR UNDER FREQUENCY	The generator output frequency has fallen below the pre-set pre-alarm setting after the <i>Safety On</i> timer has expired.
	GENERATOR OVER FREQUENCY	The generator output frequency has risen above the pre-set pre-alarm setting.
	EMERGENCY STOP	The emergency stop button has been depressed. This a failsafe (normally closed to battery positive) input and will immediately stop the set should the signal be removed. Removal of the battery positive supply from the emergency stop input will also remove DC supply from the Fuel and Start outputs of the controller. NOTE:- The Emergency Stop Positive signal must be present otherwise the unit will shutdown.
	MAGNETIC PICKUP FAILURE	Pulses are no longer being detected from the magnetic pickup probe (3110-xxx-01 magnetic pickup version only)
	INTERNAL MEMORY ERROR	Either the configuration file or engine file memory is corrupted. Contact your supplier for assistance.

8 COMMISSIONING

8.1 PRE-COMMISSIONING

Before the system is started, it is recommended that the following checks are made:-

- The unit is adequately cooled and all the wiring to the controller is of a standard and rating compatible with the system. Check all mechanical parts are fitted correctly and that all electrical connections (including earths) are sound.
- The unit **DC** supply is fused and connected to the battery and that it is of the correct polarity.
- Make all checks on the engine and alternator as detailed by their respective manufacturer documentation.
- Check all other parts in the system according to the manufacturer documentation.
- Thoroughly review the configuration of the DSE controller and check that all parameters meet the requirements of your system.
- +To check the start cycle operation, take appropriate measures to prevent the engine from starting (disable the operation of the fuel solenoid). After a visual inspection to ensure it is safe to proceed, connect the battery supply. Turn the key switch into the  position and then press the  button and the start sequence will commence.
- The starter will engage and operate for the pre-set crank period. After the starter motor has attempted to start the engine the explanation mark will illuminate.
- Restore the engine to operational status (reconnect the fuel solenoid). Turn the key switch to the  position and then to the  and press the  button. This time the engine will start and the starter motor will disengage automatically. If not then check the engine is fully operational (fuel available, etc.) and the fuel solenoid is operating. The engine will now run up to operating speed. If not, and an alarm is present, check the alarm condition for validity, and check input wiring. The engine will continue to run for an indefinite period.
- Fully commission the engine/alternator and any other parts in the system as detailed in the respective manufacturer documentation. This could includes load bank testing, load acceptance, breaker control and more
- If despite repeated checking of the connections between the **DSE701 MKII** controller and the customer's system, satisfactory operation cannot be achieved, then the customer is requested to contact the factory for further advice on:-

INTERNATIONAL TEL: +44 (0) 1723 890099

INTERNATIONAL FAX: +44 (0) 1723 893303

E-mail: support@deepseapl.com

Website: www.deepseapl.com

9 FAULT FINDING

SYMPTOM	POSSIBLE REMEDY
Unit is inoperative Read/Write configuration does not operate	Check the battery and wiring to the unit. Check the DC supply. Check the DC fuse.
Unit shuts down	Check DC supply voltage is not above 35 Volts or below 9 Volts Check the operating temperature is not above 70°C. Check the DC fuse.
Intermittent Magnetic Pick-up sensor fault	Ensure that Magnetic pick-up screen only connects to earth at one end, if connected at both ends, this enables the screen to act as an aerial and will pick up random voltages. Check pickup is correct distance from the flywheel teeth.
Unit locks out on Emergency Stop	If no Emergency Stop Switch is fitted, ensure that a DC positive signal is connected to the Emergency Stop input. Check emergency stop switch is functioning correctly. Check Wiring is not open circuit.
Low oil Pressure fault operates after engine has fired	Check engine oil pressure. Check oil pressure switch and wiring. Check configured polarity (if applicable) is correct (i.e. Normally Open or Normally Closed)
High engine temperature fault operates after engine has fired.	Check engine temperature. Check switch and wiring. Check configured polarity (if applicable) is correct (i.e. Normally Open or Normally Closed) .
Shutdown fault operates	Check relevant switch and wiring of fault indicated on LCD display. Check configuration of input..
Warning fault operates	Check relevant switch and wiring of fault indicated on LCD display. Check configuration of input.
Fail to Start is activated after pre-set number of attempts to start	Check wiring of fuel solenoid. Check fuel. Check battery supply. Check battery supply is present on the Fuel output of the controller. Check the speed-sensing signal is present on the controller's inputs. Refer to engine manual.
Continuous starting of generator when in RUN	Check that there is no signal present on the "Remote Start" input. Check configured polarity is correct.
Generator fails to start on receipt of Remote Start signal.	Check signal is on "Remote Start" input. Confirm correct configuration of input Check that the oil pressure switch is indicating low oil pressure to the controller. Depending upon configuration, then set will not start if oil pressure is not low.
Pre-heat inoperative	Check wiring to engine heater plugs. Check battery supply. Check battery supply is present on the Pre-heat output of controller. Check pre-heat configuration is correct.
Starter motor inoperative	Check wiring to starter solenoid. Check battery supply. Check battery supply is present on the Starter output of controller. Ensure that the Emergency Stop input is at Positive. Ensure oil pressure switch or sensor is indicating the "low oil pressure" state to the controller.
Engine runs but generator will not take load	Check Warm up timer has timed out. Ensure generator load inhibit signal is not present on the module inputs. Check connections to the switching device. Note that the set will not take load in manual mode unless there is an active remote start on load signal.
Controller appears to 'revert' to an earlier configuration	When editing a configuration using the PC software it is vital that the configuration is first 'read' from the controller before editing it. This edited configuration must then be "written" back to the controller for the changes to take effect.

 **NOTE:- The above fault finding is provided as a guide check-list only. As the controller is configurable for a range of different features, always refer to the source of your controller configuration if in doubt.**

Fault Finding

SYMPTOM	POSSIBLE REMEDY
<p>Incorrect reading on Engine gauges</p> <p>Fail to stop alarm when engine is at rest</p>	<p>Check engine is operating correctly. Check sensor and wiring.</p>
<p>Module appears to 'revert' to an earlier configuration</p>	<p>When editing a configuration using the PC software it is vital that the configuration is first 'read' from the controller before editing it. This edited configuration must then be "written" back to the controller for the changes to take effect.</p>
<p>Set will not take load</p>	<p>Ensure the generator is available.</p> <p>Check that the output configuration is correct to drive the load switch device and that all connections are correct.</p> <p>Remember that the set will not take load in manual mode unless a remote start on load input is present.</p>
<p>Inaccurate generator measurements on controller display</p>	<p>The 3210 controller has true RMS measuring so gives more accurate display when compared with an 'average' meter such as an analogue panel meter or some lower specified digital multimeters.</p> <p>Accuracy of the controller is better than 1% of full scale. ie Gen volts full scale is 333V ph-n so accuracy is $\pm 3.33V$ (1% of 333V).</p>



NOTE:- The above fault finding is provided as a guide check-list only. As the module can be configured to provide a wide range of different features, always refer to the source of your module configuration if in doubt.

10 MAINTENANCE, SPARES, REPAIR AND SERVICING



11 MAINTENANCE, SPARES, REPAIR AND SERVICING

The DSE3000 Series controller is designed to be *Fit and Forget*. As such, there are no user serviceable parts within the controller.

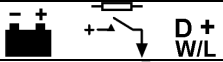

In the case of malfunction, you should contact your original equipment supplier (OEM).

11.1 PURCHASING ADDITIONAL CONNECTOR PLUGS FROM DSE

If you require additional plugs from DSE, please contact our Sales department using the part numbers below.

3000 series terminal designation	Plug description	Part No.
1-7 	7 way 5.08mm	007-447
8-9 	2 way 7.62mm	007-448
10-17 	8 way 5.08mm	007-164

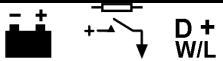
Alternatively, you can purchase a pack containing all three connectors under one part number:

3000 series terminal designation	Plug description	Part No.
1-7 	7 way 5.08mm	007-515
8-9 	2 way 7.62mm	
10-17 	8 way 5.08mm	

11.2 PURCHASING ADDITIONAL FIXING CLIPS FROM DSE

Item	Description	Part No.
	3000 series fixing clips (packet of 4)	020-294

11.3 PURCHASING SEALING GASKET FROM DSE

The optional sealing gasket is not supplied with the controller but can be purchased separately.

Item	Description	Part No.
	3000 series silicon sealing gasket	020-385

12 WARRANTY

DSE provides limited warranty to the equipment purchaser at the point of sale. For full details of any applicable warranty, you are referred to your original equipment supplier (OEM).

13 DISPOSAL

13.1 WEEE (WASTE ELECTRICAL AND ELECTRONIC EQUIPMENT)

Directive 2002/96/EC

If you use electrical and electronic equipment you must store, collect, treat, recycle and dispose of WEEE separately from your other waste.



13.2 ROHS (RESTRICTION OF HAZARDOUS SUBSTANCES)

Directive 2002/95/EC: 2006

To remove specified hazardous substances (Lead, Mercury, Hexavalent Chromium, Cadmium, PBB & PBDE's)

Exemption Note: Category 9. (Monitoring & Control Instruments) as defined in Annex 1B of the WEEE directive will be exempt from the RoHS legislation. This was confirmed in the August 2005 UK's Department of Trade and Industry RoHS REGULATIONS Guide (Para 11).

Despite this exemption, DSE has been carefully removing all non RoHS compliant components from our supply chain and products.

When this is completed, a Lead Free & RoHS compatible manufacturing process will be phased into DSE production.

This process is almost complete and is being phased through different product groups.

14 APPENDIX

14.1 COMMUNICATIONS OPTION CONNECTIONS

14.1.1 DESCRIPTION

The 3000 series configuration software allows the controller to communicate with a PC. The computer connects to the module as shown below and allows easy adjustment of the operating parameters and firmware update of the controller.

14.1.2 PC TO CONTROLLER (DIRECT) CONNECTION

To connect a 3000 series module to a PC the following items are required: -

- 3000 series module
- 3000 series configuration software (Supplied on configuration suite software CD).
- USB cable Type A to Type B.



NOTE:- The DC supply must be connected to the module for configuration by PC.

NOTE:- Refer to 3xxx software Manual for further details on configuring the module by PC.